

**24-66 VoIP**  
**Remote Base Controller**  
**Version 1.81**

**Printings:**

Version 1.00 : 07/23/04  
Version 1.01 : 09/17/04  
Version 1.10 : 02/03/05  
Version 1.11 : 03/25/05  
Version 1.60 : 04/22/05  
Version 1.70 : 08/01/06  
Version 1.80 : 12/16/09  
Version 1.81 : 01/04/19

## TABLE OF CONTENTS

<b>SPECIFICATIONS</b> .....	<b>1</b>
<b>1.0 GENERAL DESCRIPTION</b> .....	<b>2</b>
1.1 Description .....	2
1.2 Capabilities and Features .....	2
<b>2.0 INSTALLATION</b> .....	<b>3</b>
2.1 Inspection.....	3
2.2 Wall Transformer Power Supply Connection .....	3
2.3 Ethernet Connection .....	3
2.4 External Push to Talk Connection.....	3
2.5 External Headset Connection .....	3
2.6 External Handset/Desk Microphone Connection .....	3
<b>3.0 ADJUSTMENT PROCEDURES</b> .....	<b>4</b>
3.1 Handset/Desk Microphone To Ethernet Level .....	7
3.2 Desk Microphone Output Sensitivity .....	7
3.3 Internal Microphone to Ethernet Level .....	7
3.4 Headset Microphone to Ethernet Level.....	7
3.5 Speaker Level .....	7
3.6 Handset Earpiece Level .....	7
3.7 Headset Earpiece Level.....	7
<b>4.0 CIRCUIT DESCRIPTION</b> .....	<b>8</b>
4.1 Power Supply .....	8
4.2 Receive Audio .....	8
4.3 Transmit Audio .....	8
4.4 Microprocessor.....	8
4.5 Digital Signal Processor .....	9
4.6 Ethernet Interface.....	9
4.7 Keypad Board .....	9
<b>PARTS LISTS</b> .....	<b>10</b>
<b>INSTALLATION DIAGRAMS</b> .....	<b>16</b>
<b>SCHEMATICS</b> .....	<b>17</b>

## SPECIFICATIONS

Input voltage	15 Vdc @ 1000mA 24 Watt Wall Transformer 2.1 x 5.5mm barrel conn. Center (+)
Current consumption @ 15Vdc	450 mA (TX) 800 mA (RX) Vol. Max (3 watts to speaker) 400 mA (Standby)
Standby voltage	12 - 15 Vdc **
Temperature range	0 to +60 deg C
Relative humidity	90% at 50 deg C
Tx hum & noise	-60 dB (ref. +0 dBm) (When using a high bit rate CODEC)
Speaker audio output	3 W into 4 ohms
Distortion (at rated speaker output)	< 3% (When using a high bit rate CODEC)
RX hum & noise	-47 dB (ref 0dBm)
Frequency response	+1, -3 dB (300 to 3000 Hz)
Weight	3 lb.
Dimensions	4.75" (H) x 10" (W) x 8" (D)

## 1.0 GENERAL DESCRIPTION

### 1.1 Description

The 24-66 VoIP series of remote controllers is used to remotely control repeaters and base station radios. The 24-66 VoIP requires a 20-28 VoIP panel in the repeater or at the base station for correct operation. The communication between the 20-28 VoIP Termination Panel and the 24-66 VoIP Remote Controllers is done via a TCP/IP Ethernet connection. The network configuration parameters, audio configuration parameters, and one of eight different profiles for the 24-66 VoIP can be selected and changed from a computer through a web browser. The multicast set-up, CODEC algorithms, and the remote buttons profile set-up of the 24-66VoIP are stored in the 20-28 VoIP panel. All of these parameters are accessible through a WEB browser on a PC that is on the network accessing the IP Address that is assigned to the 20-28 VoIP. ***Refer to the 20-28 VoIP manual and the 20-28 VoIP online help screens for more information on this.***

TCP is one of the main protocols in TCP/IP networks, whereas the IP protocol deals only with packets, TCP enables two hosts to establish a connection and exchange streams of data. TCP guarantees delivery of data and also guarantees that packets will be delivered in the same order in which they were sent. All of the audio is sent and received as UDP packets via a multicast IP or unicast IP address and port. The 24-66 VoIP is available with either a handset or a desk microphone. A 12 Vdc power cable is also available, which allows the 24-66 VoIP to be operated from a 12 Vdc source.

### 1.2 Capabilities and Features

- ◆ TCP/IP protocol
- ◆ G.711, G.723.1, G.726 CODEC algorithms.
- ◆ Handset or desk microphone
- ◆ Desk or wall mount
- ◆ Over 99 channel capability
- ◆ Operation from 12 Vdc source
- ◆ Parallel remote update
- ◆ Intercom
- ◆ Ethernet activity indicator
- ◆ External push to talk capability
- ◆ Headset capability

## 2.0 INSTALLATION

### 2.1 Inspection

Please refer to the checklist packed with the 24-66 VoIP in order to become familiar with the unit and to insure that everything ordered has been received. In the event a part is missing from the checklist, please call the Customer Services Department at 1-701-280-1122.

This unit was thoroughly inspected before leaving the factory. If the outer package appears damaged, please inspect the unit for possible damage immediately. Any dents, scratches, or marks suggest rough handling in shipping. Please notify the shipper if you find any indications of mishandling. If there are any concerns about the condition of the 24-66 VoIP when it is received, please don't hesitate to call the Customer Services Department.

### 2.2 Wall Transformer Power Supply Connection

Connect the wall transformer power supply to power connector on the back of the 24-66 VoIP.

### 2.3 Ethernet Connection

The 24-66 VoIP allows Remote Control of a base station via an Ethernet LAN. A computer can also be connected to remote that is on the same LAN to allow the computer access to the network without the need for a hub.

The Ethernet connectors are found on the back of the 24-66 VoIP. The Ethernet cable should be a standard cable that is available anywhere that telephone and computer accessories are sold. The green link LED on the Ethernet connector should turn on showing a connection to the network. ***Refer also to the 24-66 VoIP installation diagrams in the back of this manual.***

### 2.4 External Push to Talk Connection

Connect the external push to talk switch to J2. J2 is a 3.5mm connector and is located on the side of the 24-66 VoIP next to the volume control potentiometer.

### 2.5 External Headset Connection

Connect the external headset to J3. J3 is a 2.5mm connector and is located on the side of the 24-66 VoIP between the volume control potentiometer and the handset/desk microphone connector.

### 2.6 External Handset/Desk Microphone Connection

Connect the external handset or desk microphone to J4. J4 is a RJ11 connector and is located on the side of the 24-66 VoIP next to the external headset connector.

### 3.0 ADJUSTMENT PROCEDURES

The following will explain the adjustment procedure for the 24-66 VoIP. Most audio levels are factory preset and will, in most cases, not need adjustment. All of the network settings, profile settings, and audio adjustment are accessible from a computer using a web browser. The default address is 10.0.0.200 with the subnet of 255.255.255.0. The user name is "admin" and the default password is "idacorp". Before you connect your computer to the 24-66 VoIP make sure the computers NIC is set to the same IP address range and local subnet as the 24-66 VoIP. Connect your computer directly to the 24-66 VoIP and use your web browser to access the logon screen. Once you logon you should configure the network settings to the IP address, the subnet address, and gateway address that will be used to connect to your network, also change the password to something else to protect your system. Select the "Save Changes" button before you continue.

#### Logon screen example

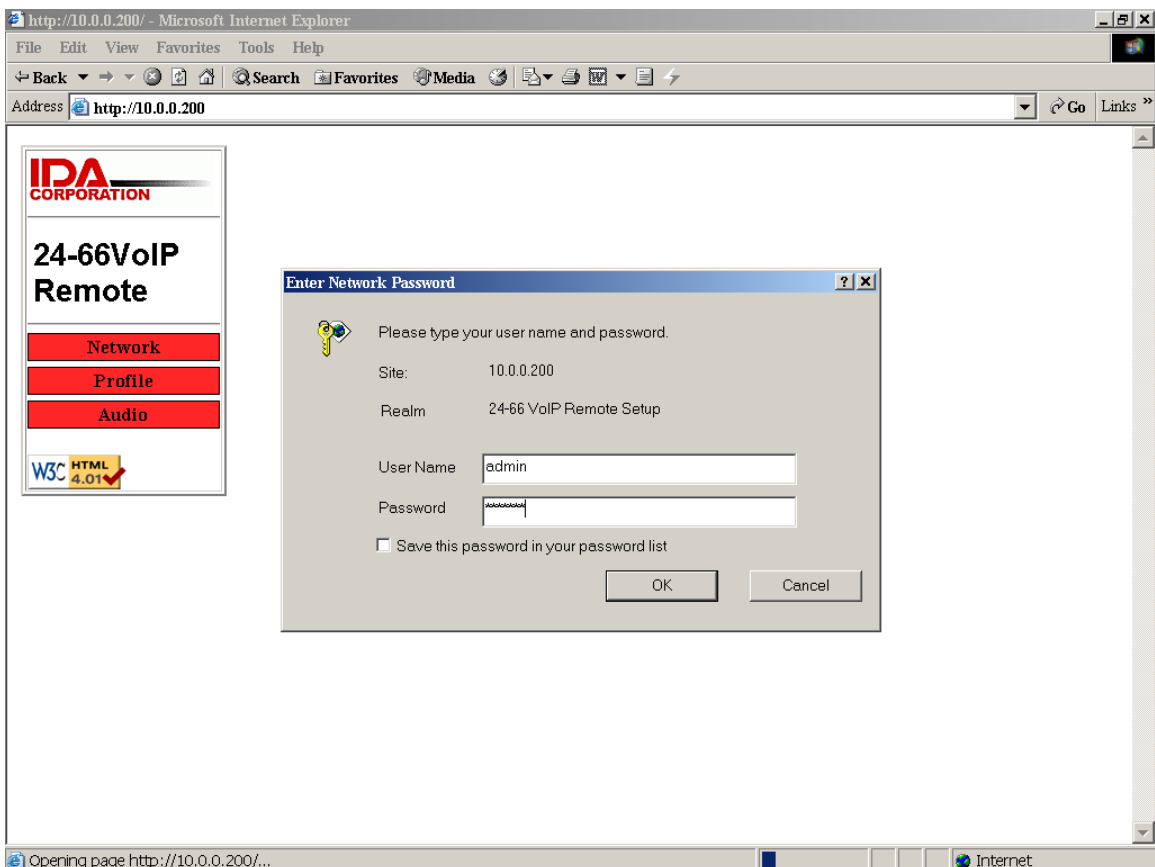

Next configure the profile settings, enter the IP address of the 20-28 VoIP panel that the 24-66 VoIP remote will connect to and select one of the eight profiles. Select the “Save Changes and Reset Unit” button. After resetting, the 24-66 VoIP network and profile changes will take affect. If you are configuring multiple 24-66 VoIP Remotes, you may need to reset the computer NIC card or restart the computer if the next 24-66 VoIP your computer is connected to does not respond. If you have the 24-66 VoIP Mini Console there will not be a profile menu but a site menu will be in its place so skip to the next page.

### 24-66 VoIP Remote Profile screen example

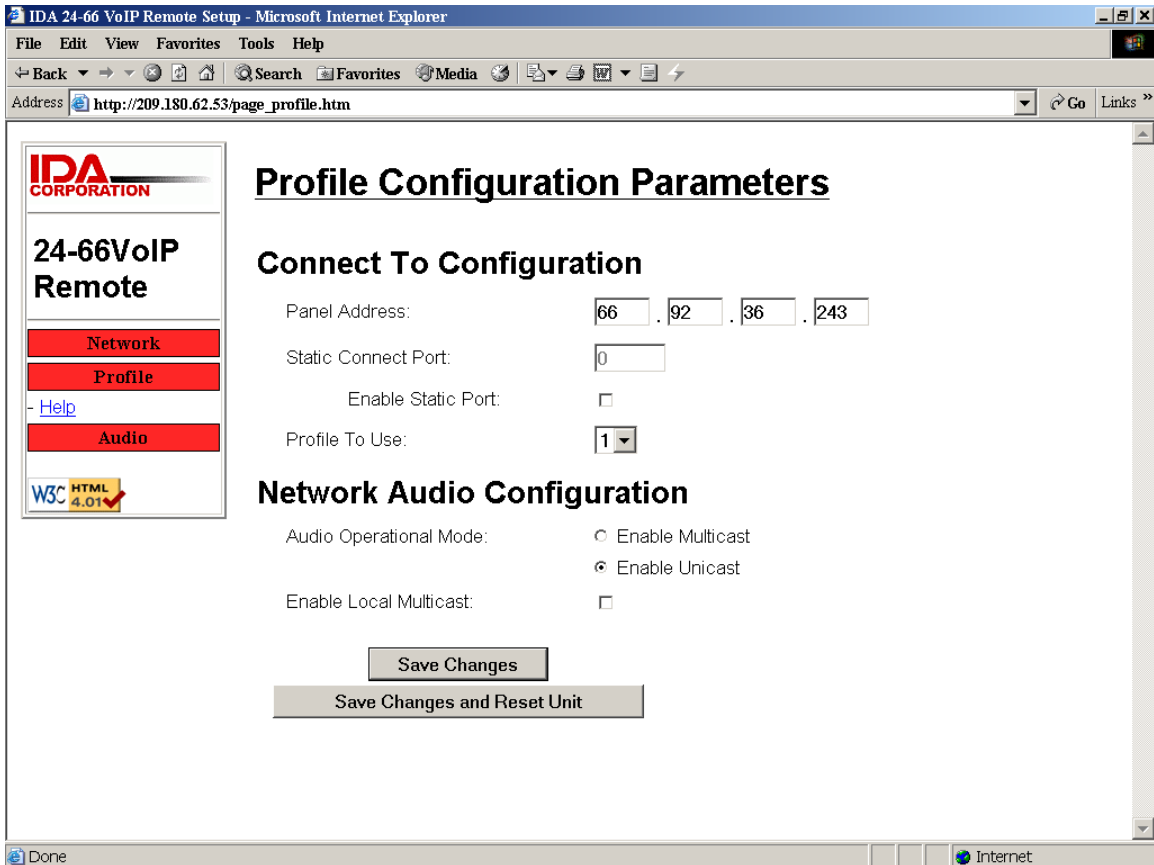

Next configure the site settings, enter the IP address of each 20-28 VoIP panel that the 24-66 VoIP Mini Console will connect to and select one of the eight profiles. Select the “Save Changes and Reset Unit” button. After resetting, the 24-66 VoIP network and profile changes will take affect. If you are configuring multiple 24-66 VoIP Remotes, you may need to reset the computer NIC card or restart the computer if the next 24-66 VoIP your computer is connected to does not respond.

### 24-66 VoIP Mini Console Site screen example

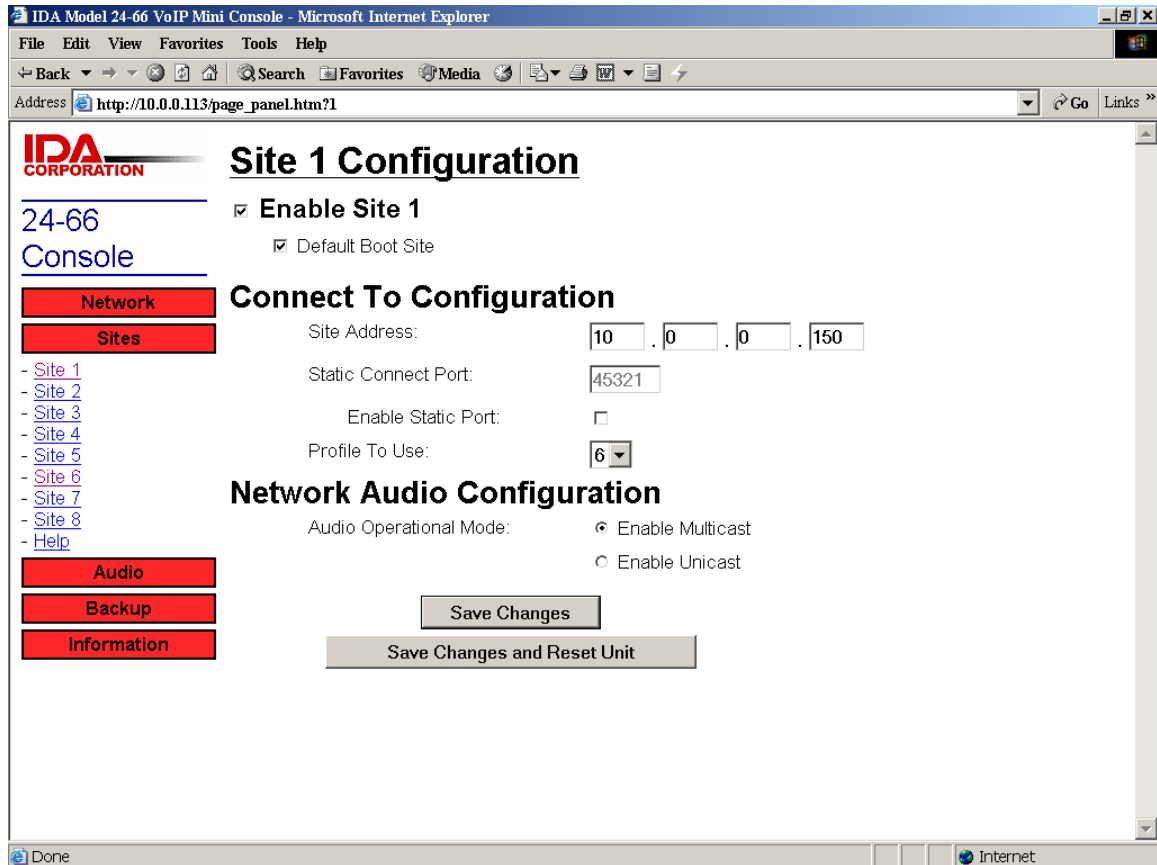



### **3.1 Handset/Desk Microphone To Ethernet Level**

The handset or desk microphone audio level is adjusted via a web browser. The level can be adjusted from -4db to 36db in 2db steps.

### **3.2 Desk Microphone Output Sensitivity**

The audio output level of the desk microphone can be adjusted through a hole in the bottom of the desk microphone. A small jeweler's flat blade screwdriver will be needed. The adjustment may need to be made depending upon background noise in the environment where the 24-66 VoIP is located and also upon the user of the desk microphone and how close and/or loud the user speaks.

### **3.3 Internal Microphone to Ethernet Level**

The internal microphone audio level is adjusted via a web browser. The level can be adjusted from -4db to 36db in 2db steps.

### **3.4 Headset Microphone to Ethernet Level**

The Headset microphone audio level is adjusted via a web browser. The level can be adjusted from -4db to 36db in 2db steps.

### **3.5 Speaker Level**

The internal speaker audio level is adjusted via a web browser. The level can be adjusted from -24db to 0db in 6db steps. While connected to the system and receiving audio from the highest-level source, adjust the level so that audio in the speaker is a comfortable listening level. Do not turn it up too high since this will cause distortion and clipping. The audio should not exceed 3.45 Vrms at the speaker terminals.

### **3.6 Handset Earpiece Level**

The handset earpiece audio level is adjusted via a web browser. The level can be adjusted from -24db to 0db in 6db steps. The handset earpiece, headset earpiece, and the base speaker are all controlled by the volume control. It may be necessary in certain noisy environments to increase the level to the earpiece. While in the noisy environment and receiving audio from the source with the least level coming in, adjust for a comfortable listening level with the volume control potentiometer at maximum.

### **3.7 Headset Earpiece Level**

The headset earpiece audio level is adjusted via a web browser. The level can be adjusted from -24db to 0db in 6db steps. The headset earpiece, handset earpiece, and the base speaker are all controlled by the volume control. It may be necessary in certain noisy environments to increase the level to the earpiece. While in the noisy environment and receiving audio from the source with the least level coming in, adjust for a comfortable listening level with the volume control potentiometer at maximum.

## **4.0 CIRCUIT DESCRIPTION**

### **4.1 Power Supply**

Power is supplied to the 24-66 VoIP via the supplied 15VDC wall transformer. It is connected at J10 on the back of the 24-66 VoIP. The polarity of the connector must be correct. From J10 the power is routed through a diode D7 and a 1 amp fuse F1. Diode D7 prevents a reverse polarity from harming the 24-66 VoIP. Power is fed into voltage regulator U18. The output voltage of U18 is set to 12.5. This 12.5 Vdc through a diode D4 drives the audio section of the 24-66 VoIP. It is also fed into voltage regulator U19 and U20. The output voltage of U19 is set to 3.3 Vdc and this 3.3 Vdc is also fed into voltage regulator U16. The output voltage of U16 is set to 1.5 Vdc. The output voltage of U20 is set to 2.5 Vdc. The 3.3 Vdc, 2.5 vdc, and the 1.5 Vdc powers the digital section of the 24-66 VoIP.

The 24-66 VoIP can be operated from a 13.8 Vdc supply through connector J12. Diode D8 prevents a reverse polarity from harming the 24-66 VoIP.

### **4.2 Receive Audio**

Receive audio UDP packets from the Ethernet interface section is passed to the microprocessor U8 for decoding. The decoded digital audio is then sent to the DSP U10. The DSP then converts the digital audio to analog and adjusts the level out.

The audio is passed to the handset earpiece at pin 2 of J5.

The audio is also fed into the speaker driver U3. U3 and its associated circuitry is a wide band audio amplifier set to have a gain of 36 dB. The output of the speaker driver goes to J11, the speaker connector. Resistor R14 is removed only if an external speaker is installed.

### **4.3 Transmit Audio**

Microphone audio from the handset or the desk microphone comes from pin 4 of J5. The microphone is biased by resistors R126 and R136. The microphone audio then passes through to the DSP U10. The DSP then converts the audio to digital. The digital audio is then sent to the microprocessor to be assembled in to UDP packets. The UDP Packets are then passed to the Ethernet section.

### **4.4 Microprocessor**

The Net+ARM 7520B MCU U8 provides the network interface functions and provides the platform for the application code. Integrated peripherals include a 10/100 Ethernet MAC, two serial ports, and numerous general-purpose I/O pins. An RTOS and a TCP/IP stack are included along with drivers for the internal peripherals.

## 4.5 Digital Signal Processor

The DSP U10 provides the audio processing functions. This DSP has six audio inputs, four audio outputs, a single Sigma-Delta CODEC, and an audio multiplexor to connect the CODEC to one audio input and one audio output. It also has numerous general-purpose I/O pins and a host interface. The DSP firmware comes pre-programmed in ROM and the functions provided can be controlled by the host CPU U8 through the host interface. The DSP firmware provides the following standard CODEC algorithms: G.711, G.723.1, G.726.

## 4.6 Ethernet Interface

The Ethernet interface consists of a three port 10/100 Base-TX Switch U4. One port is connecting externally to the LAN and the second port will connect externally to a computer to allow the computer access to the LAN. The third port will connect internally to the Ethernet port of the NET+ARM MCU U8. LEDs integrated into the Ethernet connectors will provide Connect and Activity status. The Ethernet port for connecting to the PC will be cross-wired to allow straight-through cables to be used on both ports.

## 4.7 Keypad Board

The keypad board is mounted on the faceplate of the 24-66 VoIP. It is connected to J13 on the base board by a ribbon cable that is soldered to J5 on the keypad board. The keypad board has the contacts for the front panel buttons etched on it, and provides a backplane for the front panel buttons. The rows and columns of the keypad are fed to the baseboard through connector J5. The microprocessor determines if a certain key is pressed by pulling the row input for that key low and then checking to see if the column output for that key also goes low.

LEDs are provided for each button and also for the TX indicator. These LEDs are driven by the LED display driver U1. This driver has a serial interface to the microprocessor on the base board. Serial data coming from the baseboard on pin 1 is clocked into U1 by the clock signal on pin 13. When all the data is clocked in, pin 12 is pulsed to load the data into the drivers.

Also located on the keypad board are the mounting sockets for the VU meter and LCD. The LCD plugs into J3. The VU meter plugs into either *J1* or *J2*.

## PARTS LISTS

### 24-66 VoIP Main Board

101-0291

Item	Reference	Description	Part No.	Qty
1	C1,2,12,25,28,44,46	CAP, A ELEC 47UF 6.3	381-0470R	7
2	C3,8	CAP, A ELEC 1UF 50V	381-5105R	2
3	C4,45	CAP, A ELEC 47UF 16V	381-2470R	2
4	C5,6,13,15,50,51,52,53,54,55, 56,57,58,59,60,61,63,64,65,66, 68,69,70,71,72,73,74,75,76,77, 78,79,80,81,82,83,84,85,86,87, 88,89,90,91,92,93,94,95,96,97, 98,99,100,101,102,104,105,106, 107,108,109,110,111,112,113, 114,115,116,117,118,119,121	CAP, .1UF X7R 16V	375-2104R	72
5	C7,11,17,18,20,21	CAP, A ELEC 10UF 16V	381-2106R	6
6	C9	CAP, A ELEC 2.2UF 35	381-4225R	1
7	C10,120	CAP, .47UF Y5V 16V	375-2474R	2
8	C14,26	CAP, A ELEC 4.7UF 25	381-3475R	2
9	C16,37,38,42,48	CAP, A ELEC 470UF 25	381-3471R	5
10	C19,47	CAP, A ELEC 150UF 10	381-1151R	2
11	C22,31,32,33,34	CAP, .1UF X7R 16V	375-2104R	5
12	C23,24	CAP, 22PF NPO 50V	375-5220R	2
13	C29,30,67,103	CAP, 10PF NPO 50V	375-5100R	4
14	C35,39,40	CAP, .01UF X7R 10%50	375-5103R	3
15	C36	CAP, 2700PF X7R 50V	375-5272R	1
16	C41,43	CAP TANT, 1UF 35V	392-4105R	2
17	C49	CAP .22UF Y5V 16V	375-2224R	1
18	C62	CAP, .1UF X7R 16V	375-2104R	1
19	D1,2,9,10	DIODE, SWITCH BAS16	110-2201R	4
20	D3,5	DIODE, SCHKY B140	110-2302R	2
21	D4,7,8	DIODE, SCHKY B330A	110-2301R	3
22	D6	LED, SUPER RED 0603	112-0201R	1
23	F1	FUSE PC MOUNT 1 AMP	290-0008	1
24	J1	JACK MOD, RJ45 LED	234-0121	1
25	J2	JACK SPKR PNL MNT	234-0091	1

26	J3	JACK AUDIO, 2.5mm	234-0116	1
27	J4	CONN, 7POS .1LOCK HDR	234-0006	1
28	J5	JACK, MOD 4POS SIDE	231-0021	1
29	J6	JACK MOD, RJ45 LED	234-0120	1
30	J7	CONN 36 POS R/A HDR	231-1236	0.14
31	J8	CONN 5 POS POST	231-1005	1
32	J9	CONN. 6 POS POST	231-1006	1
33	J10	CONN, R/A POWER	234-0114	1
34	J11	CONN 4POS .1 LCK HDR	234-0014	1
35	J12	CONN 2 POS .156 POST	231-1067	1
36	J13	SCKT, DIP, 16 PIN IC	220-0001	1
37	L1,5,6,7,8,9	FERRITE, 150 OHM 800	306-2001R	6
38	L3	POWER IND, 47.00uH	306-3001R	1
39	L4	POWER IND, 33.00uH	306-3002R	1
40	M1	ELEMENT, MIC, EM-50	901-0010	1
41	P1	HDR 14 POS .1 X .1	231-1076	1
42	R1	POT 50K SLIDE/AUDTAP	340-0003	1
43	R2,3,18,19,21,22,23,25,26,35, 49,113,116,118,119,130,131, 133	RES, 49.9 1% 1/16W	322-49R9R	18
44	R4,5	RES, 2K 5% 1/10W	323-1202R	2
45	R7,10,13,30,48,51,52,53,54,56, 58, 71,76,80,83,86,107,108,111, 112 120,125,132,134	RES, 10K 5% 1/10W	323-1103R	23
46	R9,12,14,15,55,78,79,81,82,98, 105,106,115,123,124,128	RES, 0 5% 1/10W	323-0000R	13
47	R11,47,122	RES, 10 5% 1/10W	323-1100R	3
48	R17,20	RES, 100 1% 1/16W	322-1000R	2
49	R32,33,37,39,40,41,42,44,45,46	RES, 33 5% 1/10W	323-1330R	10
50	R34,38,43	RES, 820 5% 1/10W	323-1821R	3
51	R36,61,62,63,64,65,66,89,95,96 97,99,101,102,103,104,109,127 129,136	RES, 1K 5% 1/10W	323-1102R	20
52	R50	RES, 499K 1% 1/16W	322-4993R	1
53	R60	RES, 56 5% 1/10W	323-1560R	1
54	R67	RES, 10M 5% 1/10W	323-1106R	1
55	R68,69	RES, 9.31k 1% 1/4W	326-9311R	2
56	R70	RES, 7.15K 1% 1/4W	326-7151R	1
57	R72	RES, 300 5% 1/10W	323-1301R	1
58	R73	RES, 1k 1% 1/4W	326-1001R	1
59	R74,75	RES, 75K 5% 1/10W	323-1753R	2
60	R77	RES, 0 5% 1/10W	323-0000R	1
61	R90	RES, 2.7K 5% 1/10W	323-1272R	1
62	R94	RES, 1M 1% 1/16W	322-1004R	1
63	R110	RES, 3.01K 1% 1/16W	322-3011R	1
64	R121	RES, 1 5% 1/10W	323-11R0R	1
65	R126	RES, 620 5% 1/10W	323-1621R	1
66	U1	IC, 24LC256	131-1060	1

67	U2	IC, MCP3221A5T-I/OT	131-5001	1
68	U3	IC, TPA1517DWPR	131-1061	1
69	U4	IC, KS8993	131-2009	1
70	U5,15	IC, SN74AHC1GO8DBVR	131-5002	2
71	U6	IC, TC1270TERCT-ND	131-5003	1
72	U7	IC, SN74AHC1GO8DBVR	131-5002	1
73	U8	IC, NS7520B-1-C55	131-6000	1
74	U9,14	IC, HY57V161610DTC-7	131-1064	2
75	U10	IC, VP101X12BQC-1	131-2010	1
76	U11	IC, MAX3232ESE	131-1062	1
77	U12	IC, SN74LVC1GU04DBVR	131-5005	1
78	U13	IC, AM29LV800BT120	131-1063	1
79	U16	IC, LP3984IMF-1.5	131-5004	1
80	U17	IC, XC9572XL-10PC44C	131-3010	1
81	U18	IC, LM2673S-ADJ	131-4001	1
82	U19	IC, LM2673S-3.3	131-4002	1
83	U20	IC, LM1086CS-5.0	131-4003	1
84	U21	IC, LM1086CS-2.5	131-4004	1
85	Y2	CRY, 18.432 MHZ 20PF	305-0101R	1
86	Y3	CRY, 25.000MHZ 18PF	305-0103R	1
87	Y4	CRY, 4.096MHA 20PF	305-0102R	1
88	00	PC BD, VoIP RMT MAIN	900-0291	1
89	00	MOUNT, RBR .SHACK 80A	901-0011	1

**24-66 VoIP Keypad Board  
101-0316**

<b>Item</b>	<b>Reference</b>	<b>Description</b>	<b>Part No.</b>	<b>Qty.</b>
1	C1,2	10uF 16V ELEC CAP	381-2106	2
2	C3	10uF 16V ELEC CAP	381-2106	1
3	C4,6	NOT INSTALLED	000-0002	2
4	C5	.1uF 16V 10% MONO CAP	375-2104	1
5	D1	NOT INSTALLED	000-0002	1
6	D2,3,4,5,6,7,8,9,10, 11,12,13	LED, T-1 RED	112-0012	12
7	D14	LED, RED HIGH INTENSITY	112-0024	1
8	J1,2,3,4	NOT INSTALLED	000-0002	4
9	J5	16 POS CABLE 8"	222-0025	1
10	JP1,2	STAPLE JUMPER	265-0016	2
11	R1,6	220 1 W RES	314-1224	2
12	R2	1.2K 5% 1/10 W RES	323-1122	1
13	R3,5,7	10K 5% 1/10 W RES	323-1103	3
14	R4	33K 5% 1/10 W RES	323-1333	1
15	R8	NOT INSTALLED	000-0002	1
16	U1	MAX7219, IC	131-1108	1
17	U2	NOT INSTALLED	000-0002	1
18		KEYPAD PC BOARD	900-0316	1

**VU Meter Option (New)**

<b>Item</b>	<b>Reference</b>	<b>Description</b>	<b>Part No.</b>	<b>Qty.</b>
1	D1,2	10 SEGMENT BAR LED	112-0027	2
2	P1	12 POS HEADER POST	231-3315	1
3	U2	LM3915 IC	130-0372	1
4		PLASTIC STANDOFF .125"	200-0388	2
5		VU METER PC BOARD	900-0281	1

**LCD Option**

<b>Item</b>	<b>Reference</b>	<b>Description</b>	<b>Part No.</b>	<b>Qty.</b>
1	C4,6	.1uF 16V 10% MONO CAP	375-2104	2
2	J1	6 POS RECEPTACLE	231-1116	2
3	J3	8 POS RECEPTACLE	231-3008	2
4	R8	10K 1 TURN POT	351-1103	1
5	U2	74HC595, IC	131-1107	1
6		LCD 32 CHARACTER	113-0106	1
7		PLASTIC STAND OFF 1/8"	200-0311	4
8		16 POS HEADER POST	231-3116	1

**Desk Mic Option**

<b>Item</b>	<b>Description</b>	<b>Part No.</b>	<b>Qty.</b>
1	DESK MIC	900-0399	1
2	CABINET TOP	900-0802	1

**Hand Set Option**

<b>Item</b>	<b>Description</b>	<b>Part No.</b>	<b>Qty.</b>
1	HOLE COVER	199-6137	1
2	CABLE TIE (SHORT)	200-0081	2
3	SENSOR SWITCH	611-0027	1
4	HAND SET	900-0020	1
5	CABINET TOP	900-0801	1

#### Ethernet Cable Option

Item	Description	Part No.	Qty.
1	10 FT Ethernet Cable	800-2080	1

#### DC Power Cable Option

Item	Description	Part No.	Qty.
1	2 POS .156 RECEPTACLE	233-0024	1
2	CABLE TIE (SHORT)	200-0081	1
3	2 COND. 20ga. CABLE	800-1106	5'

#### External Encode/Decode Cable Option

Item	Description	Part No.	Qty.
1	CABLE TIE (SHORT)	200-0081	1
2	9 COND. 22ga. CABLE	222-0034	3'
3	5 POS .1" RECEPTACLE	233-0024	1
4	2 POS .1" RECEPTACLE	234-0033	1

#### Wall Mount Option

Item	Description	Part No.	Qty.
1	WALL BRACKET	900-5112A	1
2	6 x 1/4" SF THRD SCREW	199-4039	4
3	6 x 1" SHEET MTL SCREW	199-4011	4
4	WALL ANCHOR	199-4012	4



### 24-66 Base Cabinet

Item	Description	Part No.	Qty.
1	NUT PAL	199-0040	4
2	#6 FLAT WASHER	199-2106	2
3	6-32 X 1/4" SCREW	199-3070	1
4	#4 X 1/4" TAP SCREW	199-4029	9
5	#6 X 3/8" TAP SCREW	199-4038	7
6	#6 X 1/4" TAP SCREW	199-4039	6
7	6 KEY, KEYPAD	203-0032	1
8	3 KEY, KEYPAD	203-0033	2
9	3/8" FOOT	203-1053	4
10	22 AWG WIRE GREEN	222-0016	6"
11	22 AWG WIRE YELLOW	222-0018	6"
12	4 POS RECEPTACLE	233-0045	1
13	REMOTE BUTTON	900-0805	12
14	12 KEY PANEL SCREENED	900-0803S	1
15	BOTTOM CABINET	900-0800	1
16	CRYSTAL for LCD	900-0737	1
17	WEIGHT VoIP	900-5008C	1
18	3W 4ohm SPEAKER	901-0004	1
19	WALL TRANSFORMER	902-0015	1

## Multicast / Unicast Typical Installation Example

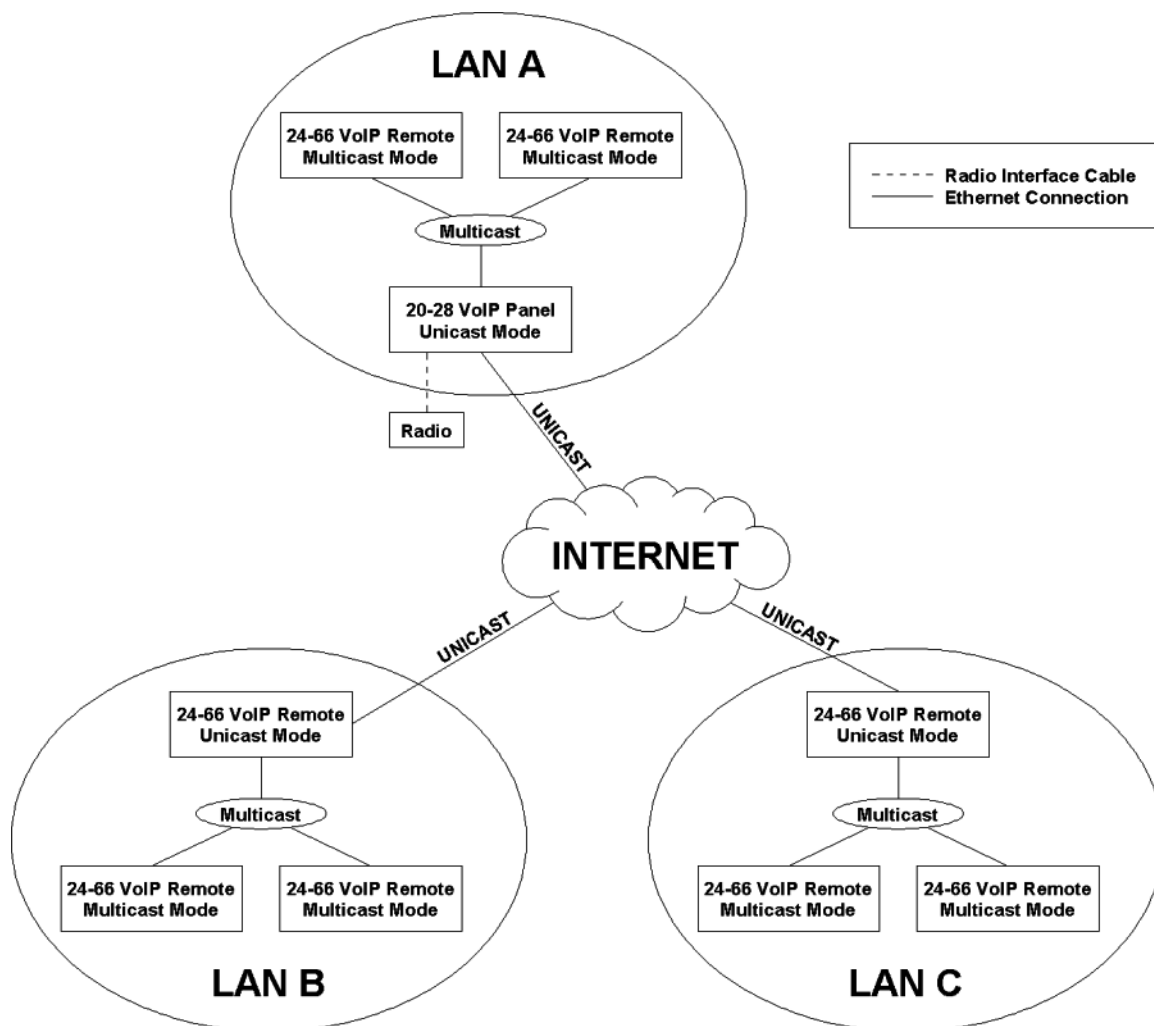

Since Multicast across the Internet is not supported in all most cases, the 20-28 VoIP and the 24-66 VoIP units connected to the Internet can be configured for Unicast. The 20-28 VoIP (at one LAN) and any 24-66 VoIP's (at other LAN's) connected to the Internet are configured for Unicast. The remaining 24-66 VoIP's at each LAN are configured for Multicast. The units configured for Unicast also provide a Multicast repeat of the audio to the remaining units at their particular LAN.

**Note: The 24-66 MC does not support Multicast repeat of the audio to the remaining units at their LAN.**

# 24-66 VoIP INSTALLATION DIAGRAM

110 VAC Outlet  
(Front View)

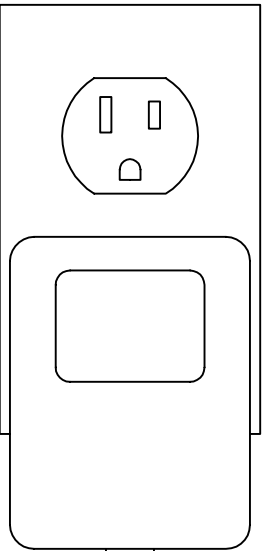

Wall Transformer

Power Cord

24-66 VoIP Remote Base Controller  
(Rear View)

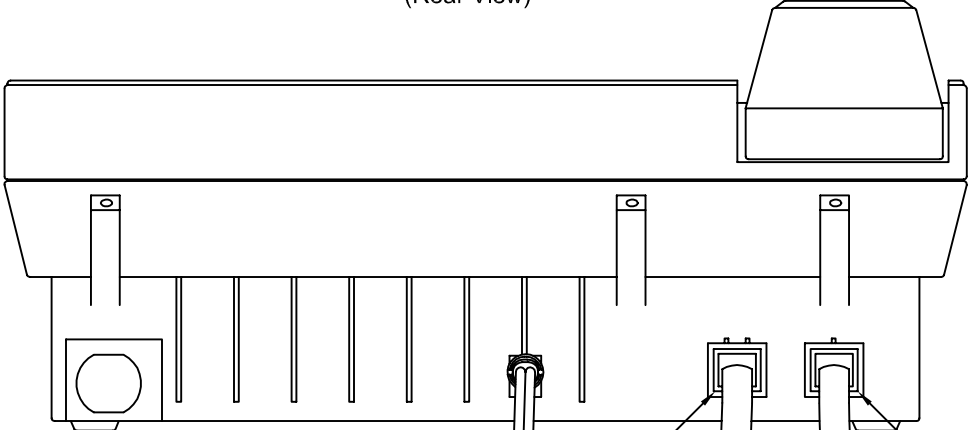

J6

J1

LAN Connection  
Ethernet Hub or a 20-28  
VoIP Ethernet 

Ethernet   
Local computer connection  
or an additional 24-66 VoIP  
Remote (J6)

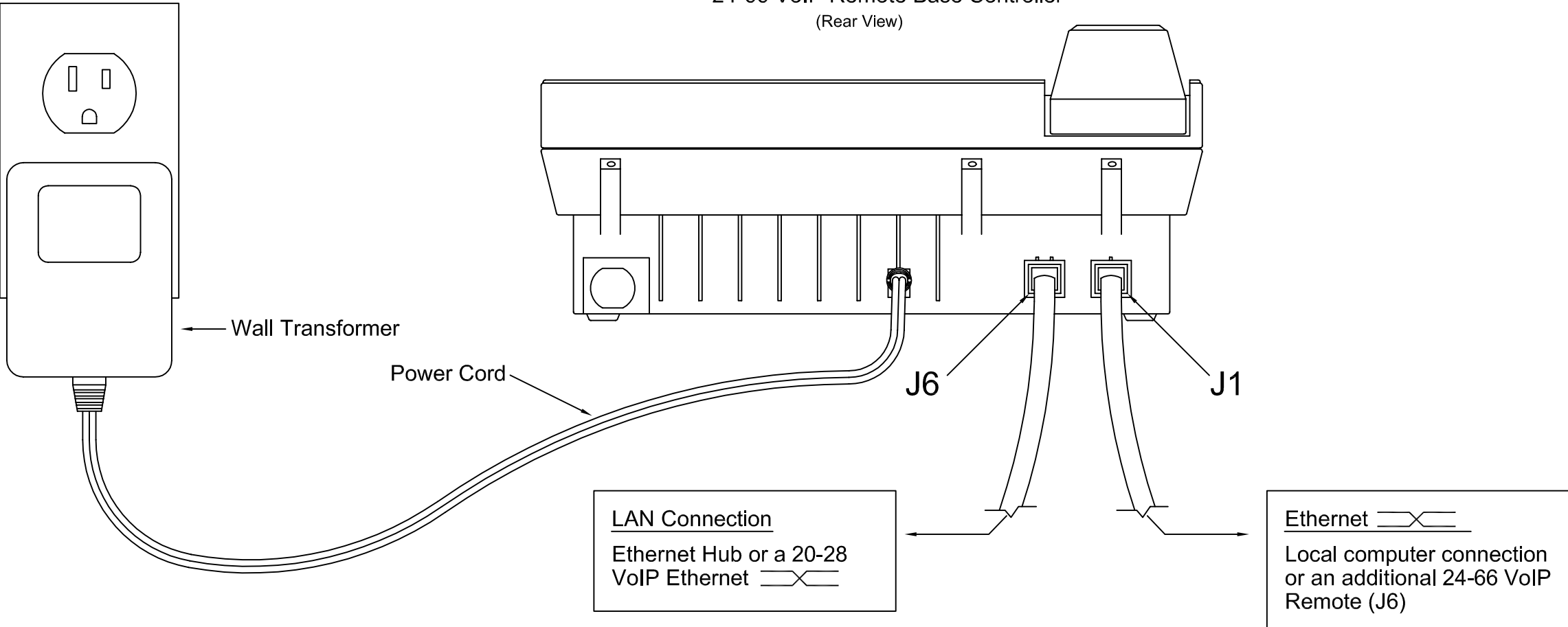

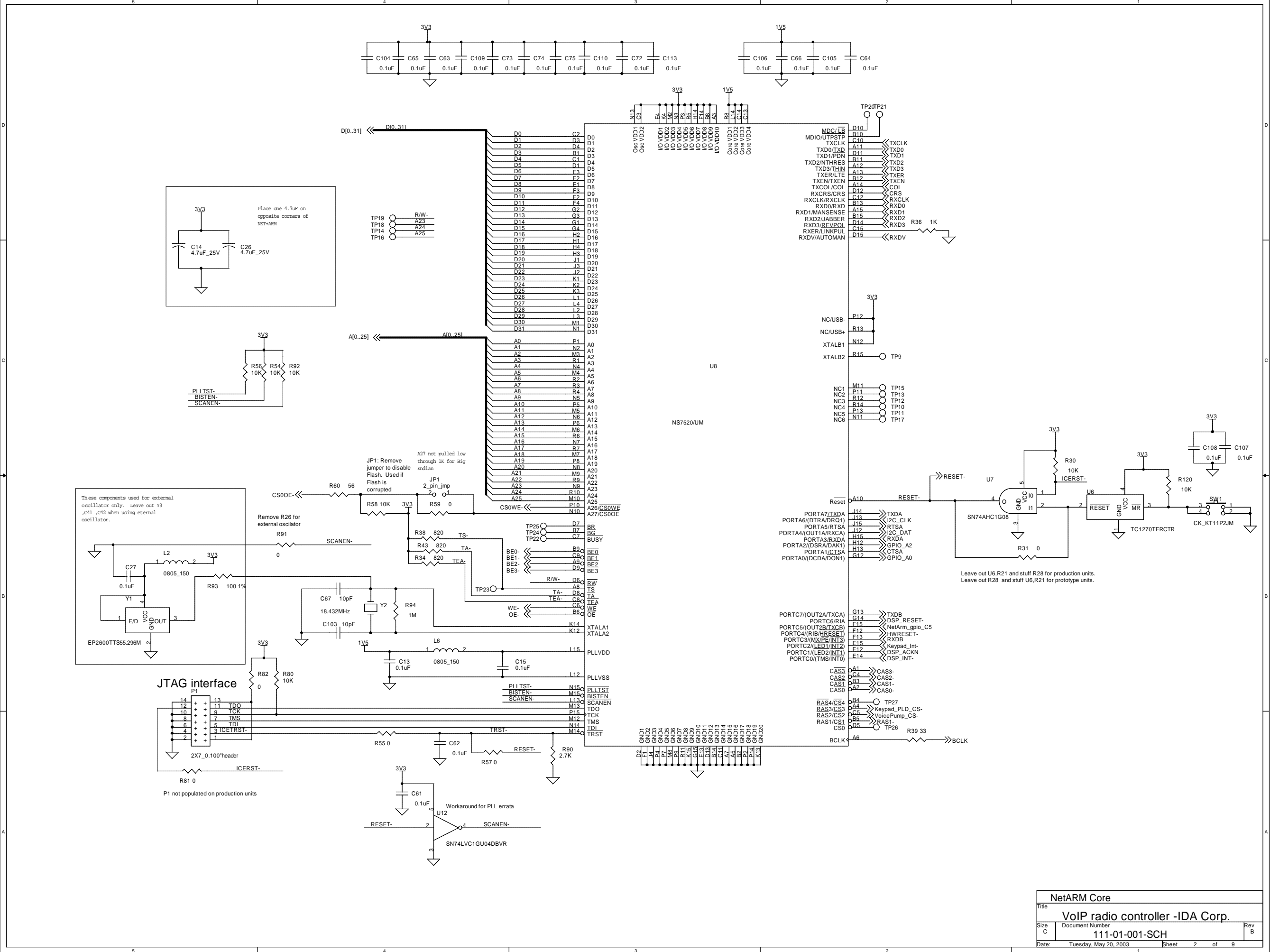

Place one 4.7uF on opposite corners of NET-ARM

PLLTST-  
BISTEN-  
SCANEN-

These components used for external oscillator only. Leave out Y3, C41, C42 when using external oscillator.

JTAG interface  
P1 not populated on production units

JP1: Remove jumper to disable Flash. Used if Flash is corrupted

Leave out U6, R21 and stuff R28 for production units. Leave out R28 and stuff U6, R21 for prototype units.

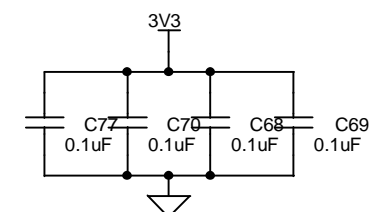
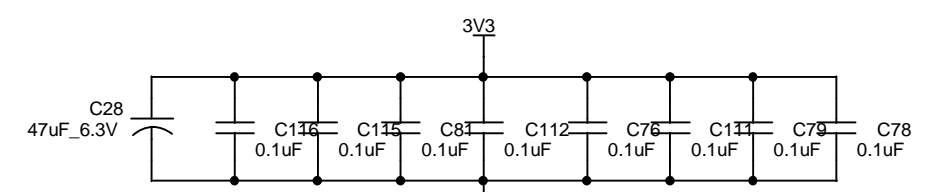
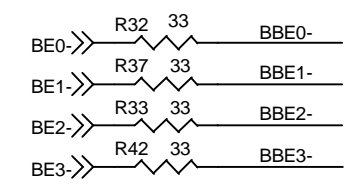
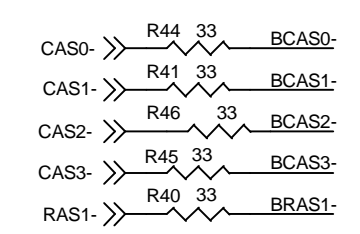
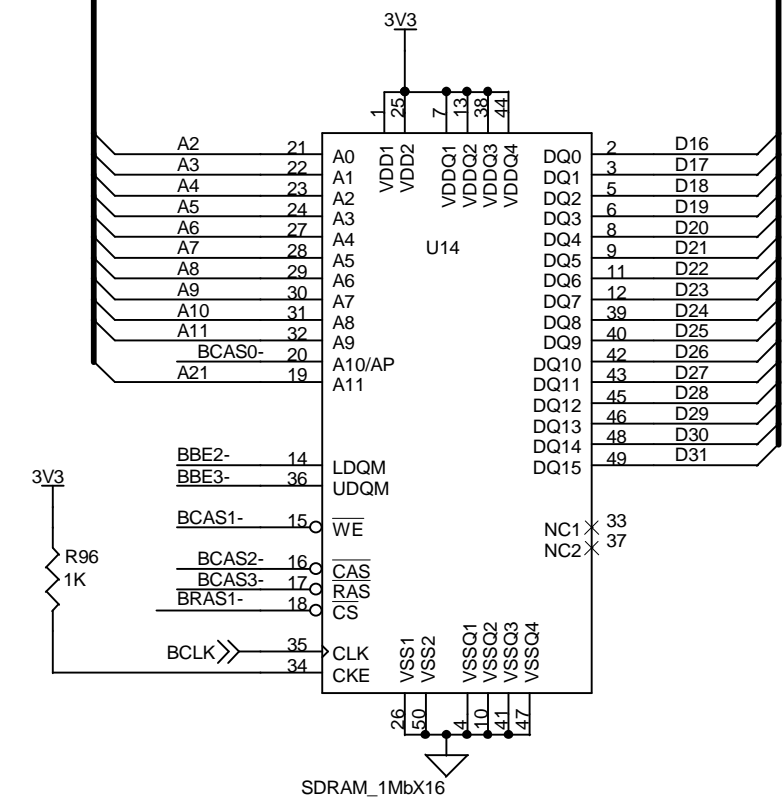
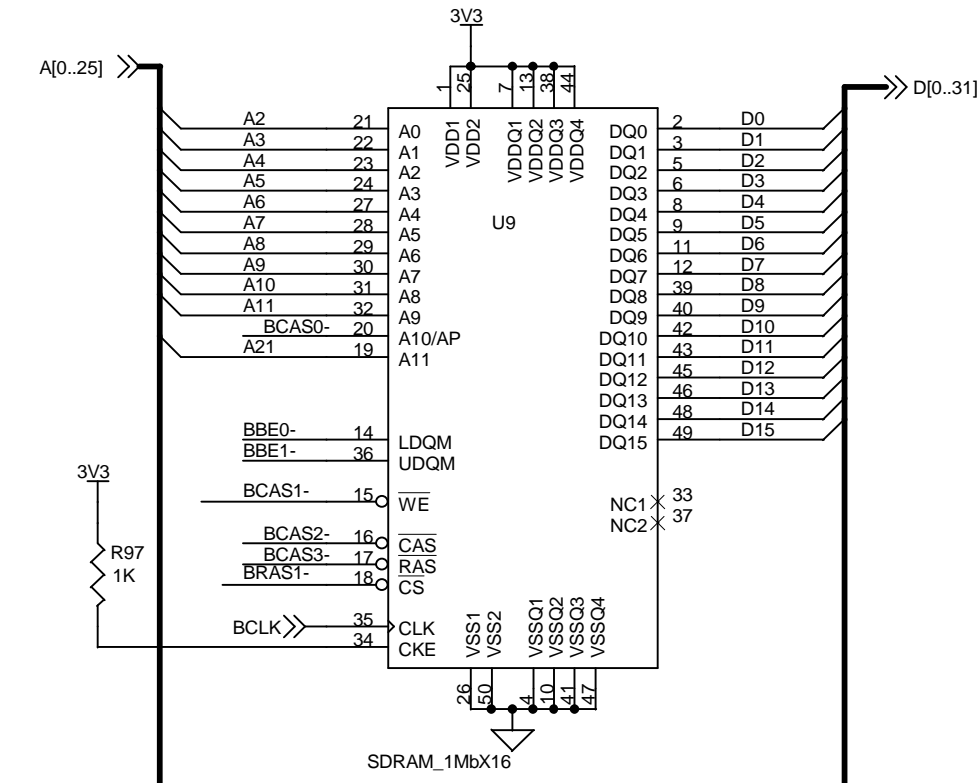
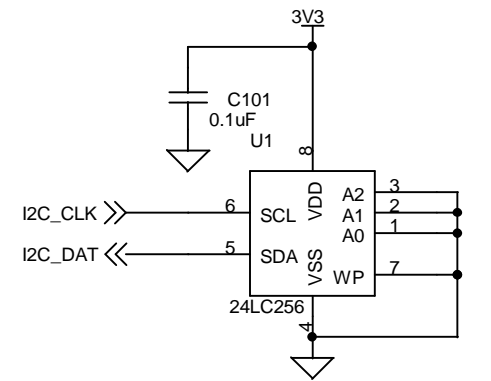
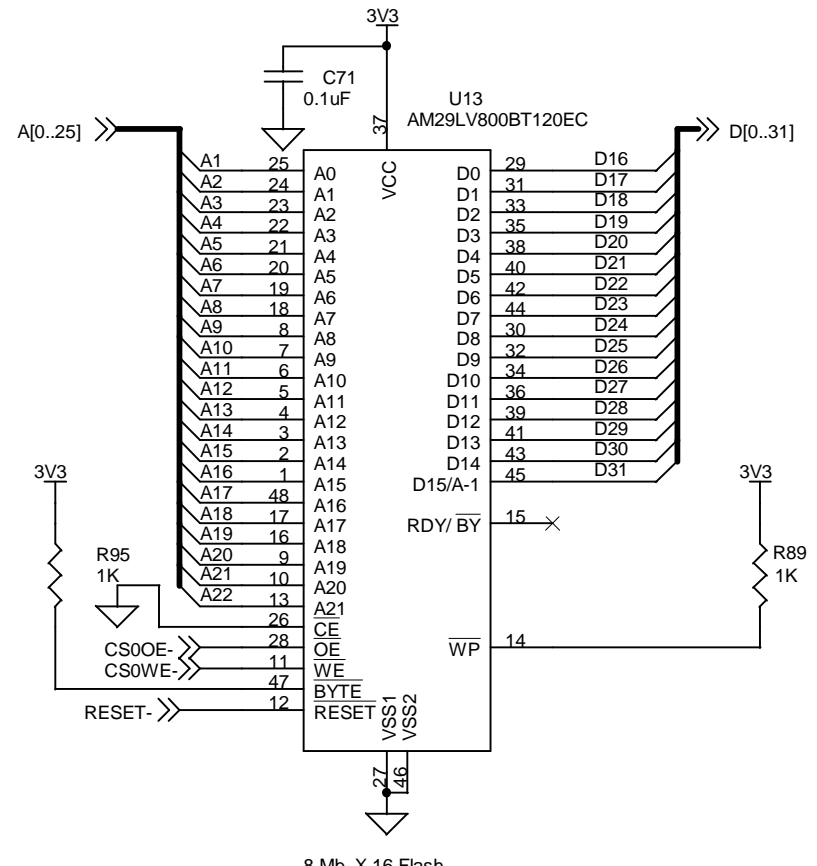

Flash,SDRAM and Serial EEprom		
Title		
VoIP radio controller -IDA Corp.		
Size B	Document Number	Rev B
	111-01-001-SCH	
Date: Tuesday, May 20, 2003	Sheet 3 of 9	

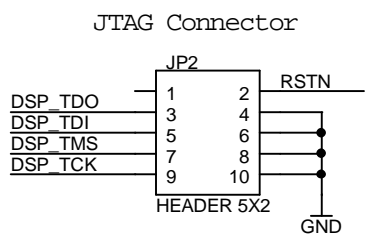
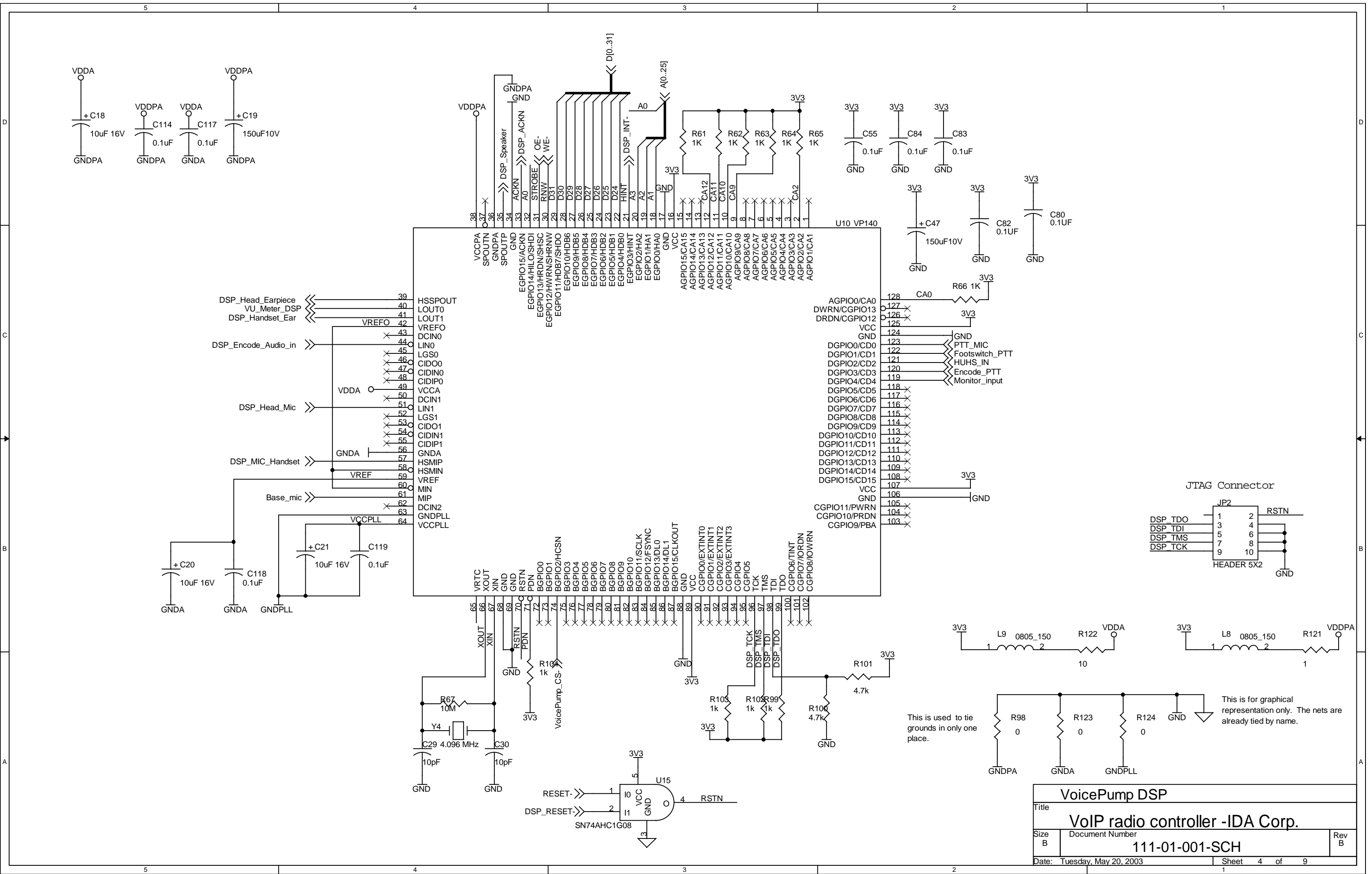

This is used to tie grounds in only one place.

This is for graphical representation only. The nets are already tied by name.

VoicePump DSP		
Title		
VoIP radio controller -IDA Corp.		
Size	Document Number	Rev
B	111-01-001-SCH	B
Date:	Tuesday, May 20, 2003	Sheet 4 of 9

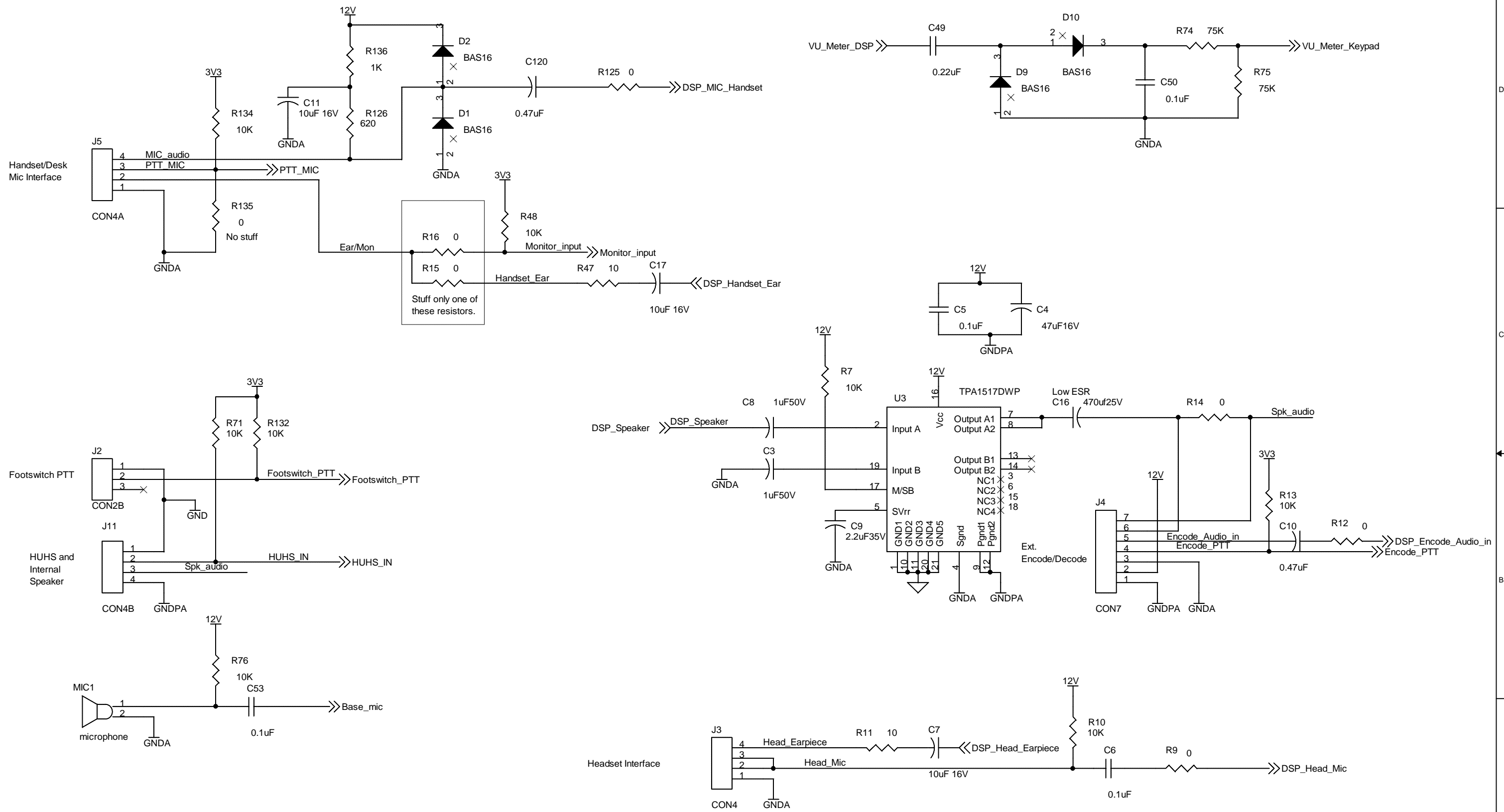

DSP Front end circuitry		
Title		
VoIP radio controller -IDA Corp.		
Size	Document Number	Rev
B	111-01-001-SCH	B
Date:	Tuesday, May 20, 2003	Sheet 5 of 9





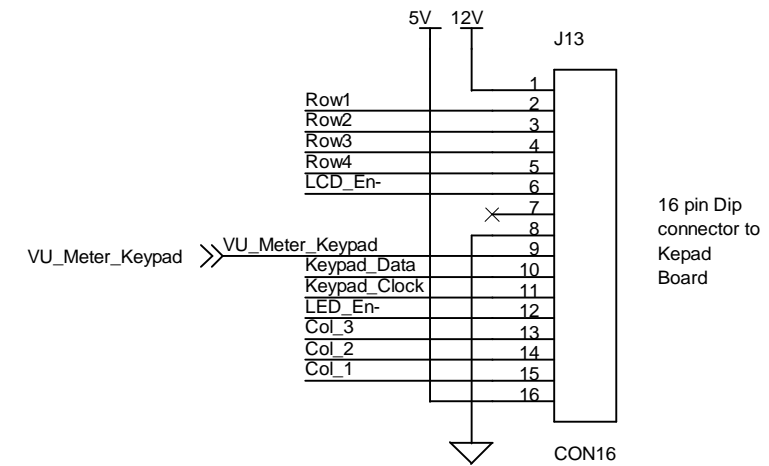
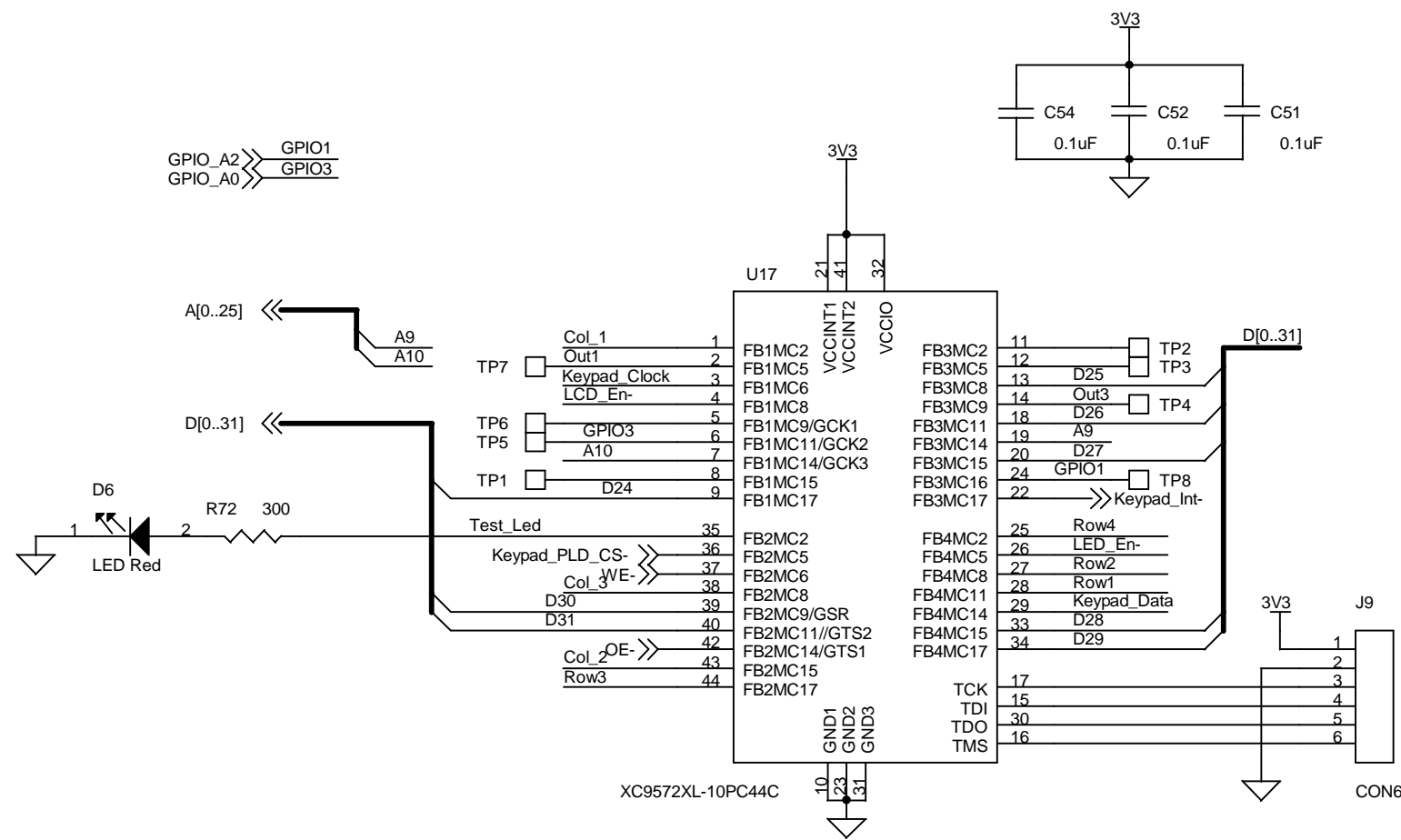

Keypad Interface Board		
Title		
VoIP radio controller -IDA Corp.		
Size	Document Number	Rev
B	111-01-001-SCH	B
Date:	Tuesday, May 20, 2003	Sheet 7 of 9
		1

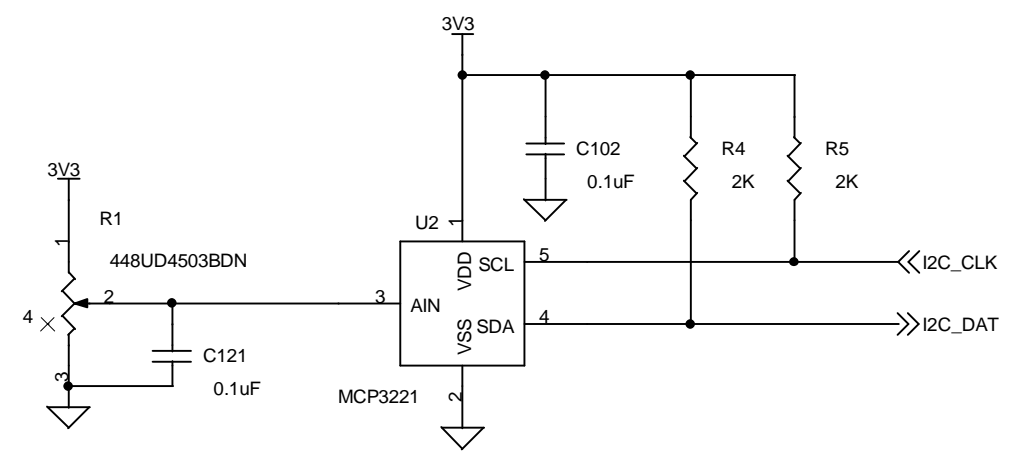
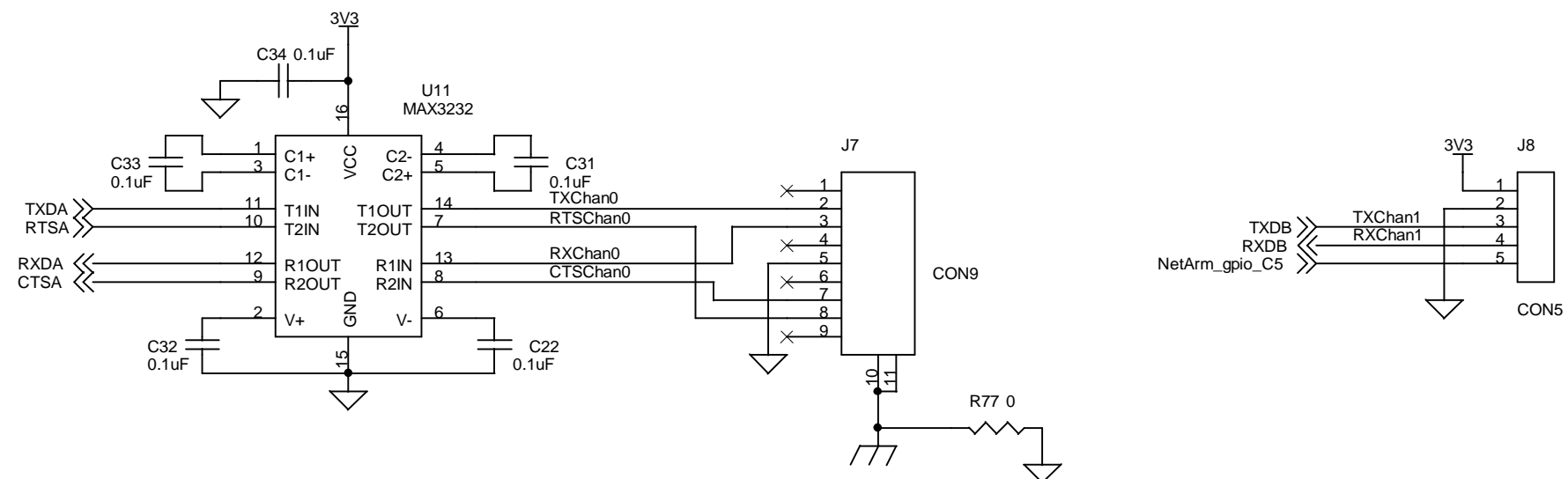

Serial Ports and Volume control Pot and A to D		
Title	VoIP radio controller -IDA Corp.	
Size B	Document Number	Rev B
	111-01-001-SCH	
Date: Tuesday, May 20, 2003	Sheet 8 of 9	1

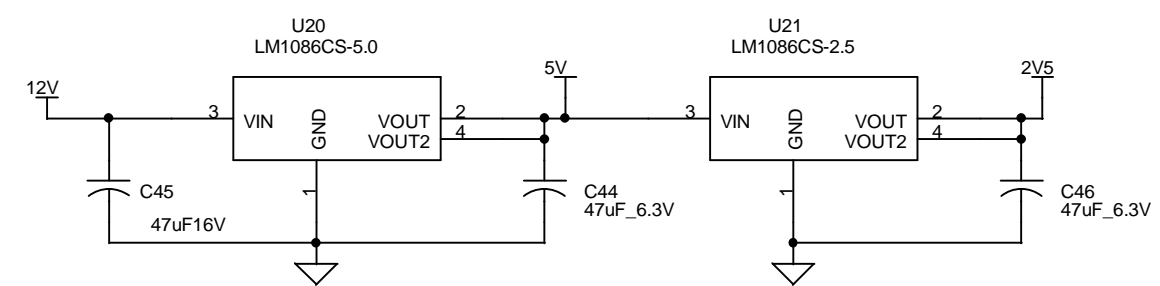
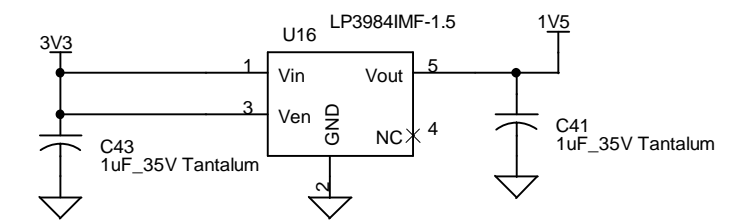
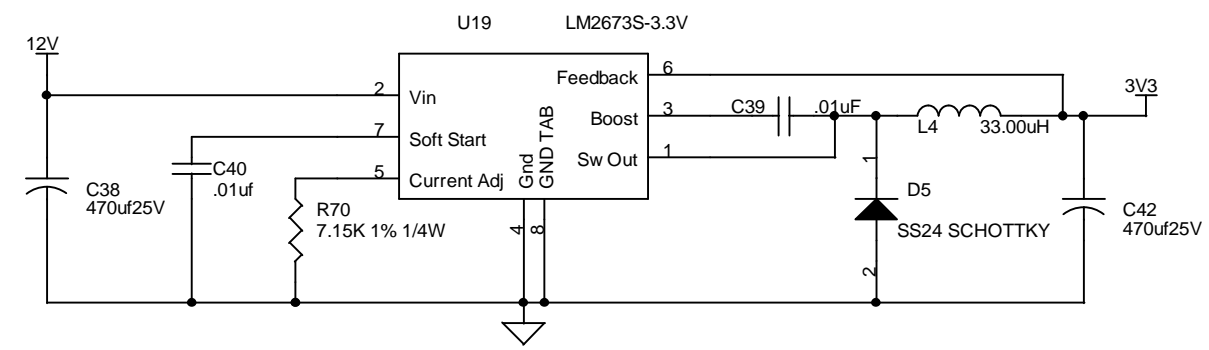
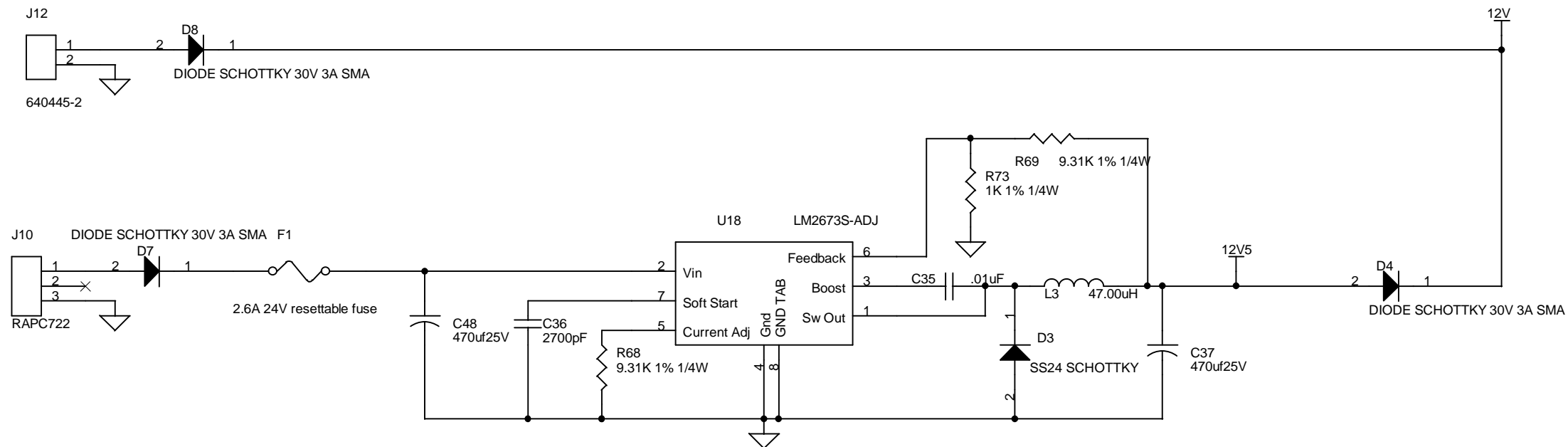

Power Supply		
Title		
VoIP radio controller -IDA Corp.		
Size	Document Number	Rev
B	111-01-001-SCH	B
Date:	Tuesday, May 20, 2003	Sheet 9 of 9

