

24-67

Remote Base Controller

Version 1.00

Printings:

Version 1.00: 11/13/2012

TABLE OF CONTENTS

SPECIFICATIONS	1
1.0 GENERAL DESCRIPTION	2
1.1 Description	2
1.2 Capabilities and Features	2
2.0 INSTALLATION	3
2.1 Line Connection	3
2.2 Proper Grounding Practices.....	3
2.3 Switch Settings.....	3
2.4 Remote Control Applications.....	4
3.0 ADJUSTMENT PROCEDURES	10
3.1 Microphone To Line Level.....	10
3.2 Desk Microphone Output Sensitivity	10
3.3 Internal Microphone Level.....	10
3.4 R28 and R39 - 2175 Hz Notch Filter Adjust	11
3.5 Tone Encode Level	11
3.6 MSK Encode Level (MSK Control Option is not available at this time)	11
3.7 DTMF Encode Level	11
3.8 Receive Line Compensation	11
3.9 Summed Audio Level	12
3.10 Speaker Level	12
3.11 Earpiece Level	12
3.12 R29 and R40 - 2175 Hz Notch Filter Adjust	13
3.13 R32 - Guard/Hold Tone Detect	13
4.0 CIRCUIT DESCRIPTION	14
4.1 Power Supply	14
4.2 Line Interface	14
4.3 Two Wire, No Supervisory, No Alternate Line.....	14
4.4 Two Wire With Supervisory	14
4.5 Two Wire With Alternate Line.....	14
4.6 Four Wire, No Supervisory, No Alternate Line	15
4.7 Four Wire With Supervisory	15
4.8 Four Wire With Alternate Line	15
4.9 Two Wire With Alternate Line Summed Audio	16
4.10 Combined Two Wire and Four Wire (for use with 20-88)	16
4.11 Receive Audio	16
4.12 Transmit Audio	17
4.13 Digital Control Section.....	18
4.14 MSK Interface (MSK Control Option is not available at this time).....	20
4.15 Parallel Detect.....	20
4.16 Keypad Board	20
4.17 Clock Option.....	21
4.18 VU Meter Option	21
4.19 LCD Option	21
4.20 Programming Cable	21

4.21 Proper Grounding.....	22
5.0 TROUBLESHOOTING.....	24
5.1 Microphone Audio Doesn't Reach the Line.....	24
5.2 VU Meter Doesn't Function.....	24
5.3 Control/Alert Tones Do Not Reach the Line.....	25
5.4 Control Tones Have No Effect on the Panel.....	25
5.5 Line Audio Doesn't Reach the Speaker.....	25
5.6 Earpiece Audio is Not Loud Enough or No Sound.....	26
5.7 A Constant Hum is Present in the Speaker.....	26
5.8 Background Tone (2175 Hz) Present in Receive Audio.....	26
5.9 Parallel TX Indicator Intermittent or Stuck On.....	27
5.10 One or More Keys Stuck On or Off.....	27
5.11 Faceplate Keys and All LEDs Inoperative.....	27
5.12 Microprocessor Functioning Improperly.....	27
5.13 Status Messages.....	28
PARTS LIST.....	30
TEST MODE APPENDIX.....	38
INSTALLATION DIAGRAMS.....	49
ADJUSTMENT LOCATOR DIAGRAM.....	51
SCHEMATICS.....	52

SPECIFICATIONS

Input voltage	15 Vdc @ 1000mA 24 Watt Wall Transformer 2.1 x 5.5mm barrel conn. Center (+)
Standby voltage	12 - 15 Vdc
Standby current @ 13.8 Vdc	287 mA (TX) 645 mA (RX) 267 mA (Standby)
Input power (max)	8.5 W (TX) 20 W (RX) 8.5 W (Standby)
Temperature range with LCD	0 to +60 deg C 0 to +50 deg C
Relative humidity	90% at 50 deg C
Line impedance	600 ohms (4-wire RX) 600 or > 5k ohms (4-wire TX or 2-wire)
Line audio output	-10 dBm to +10 dBm into a 600 ohm load
Tx hum & noise	-55 dB (ref. +10 dBm)
Threshold of compression (line to speaker audio)	-20 dBm adjustable
Speaker audio output	3 W into 4 ohms
Distortion (at rated speaker output)	< 3%
RX hum & noise	-55 dB
Frequency response	+1, -3 dB (300 to 3000 Hz except at notch frequency)
Rx Compression	With an audio increase of 30 dB beyond the start of compression the output increases less than 3 dB.
Tx Compression	With an audio increase of 30 dB beyond the start of compression the output increases 15 to 17 dB.
Line control	2 or 4 wire audio
Notch filter depth	> 45 dB (RX) > 45 dB (TX)
Weight	5 lb.
Dimensions	4.75" x 10" x 8"

1.0 GENERAL DESCRIPTION

1.1 Description

The 24-67 series of remote controllers is used to remotely control repeaters and base station radios. Tone sequences are used by the 24-67 to control the remote repeater or base station radio. The 24-67 requires an appropriate panel in the repeater or at the base station for correct operation. The operating characteristics of the 24-67 can be selected and changed with the programming software which runs on a standard personal computer.

The 24-67 is available with either tone signaling or MSK signaling (**MSK is not available at this time**). The 24-67 Tone remote uses function tones from 550 to 2050 Hz to control the repeater or base station radio while the 24-67 MSK remote uses an MSK modem for control. The 24-67 is available with either a handset or a desk microphone and can operate with either a 2-wire or a 4-wire line. The 24-67 provides parallel detect as well as alternate line and supervisory modes of operation. The 24-67 is available with clock and VU meter display and can be set on a desk or wall mounted. A 12 V power cable is also available which allows the 24-67 to be operated from a 12 Vdc source.

1.2 Capabilities and Features

- ◆ Tone or MSK signaling (**MSK is not available at this time**)
- ◆ 2 wire or 4 wire operation
- ◆ Handset or desk microphone
- ◆ Desk or wall mount
- ◆ PC programmable
- ◆ Non-volatile memory
- ◆ 8 or 99 channels for 24-67 Tone remote
- ◆ 99 channels or up to 32 systems for 24-67 MSK remote
- ◆ Operation from 12 Vdc source
- ◆ Parallel remote update
- ◆ Full duplex operation
- ◆ Intercom
- ◆ Alert tone
- ◆ Supervisory option
- ◆ Alternate line with or without summed audio option
- ◆ Clock option
- ◆ VU meter option
- ◆ LCD option

2.0 INSTALLATION

2.1 Line Connection

The 24-67 allows either 2-wire or 4-wire lines to be used. The choice of which one of these to use should be based upon cost, availability, performance, and the conditions that the 24-67 is to operate within. Two wire lines have one voice grade pair that is used for both the transmit and receive audio. They are simple to install and, depending upon local service, may be more economical. Four wire lines provide two voice grade pairs, one for transmit audio and the other for receive audio. This provides full duplex operation allowing the 24-67 to transmit and receive at the same time. Cost may be a factor since two voice grade pairs are required. Four wire lines would be used with customer owned multiplex microwave systems and with leased lines that do not use hybrids in the transmission paths.

The line connectors are found on the back of the 24-67. Connector J5 is the primary connector and is marked with one notch in the plastic case. Connector J6 is the secondary connector and is marked with two notches in the plastic case. The line should be a standard 2 or 4 wire cable that is available anywhere that telephone accessories are sold. With more than one remote in the system and no alternate line or supervisory option installed, J5 is used for the line from the base station and J6 is used to connect the line to additional remotes. With the supervisory option installed, J6 is used for the line from the base station and J5 connects to the remotes under supervisory control. If the 24-67 has the alternate line option installed, J5 is used for the primary line and J6 is used for the alternate line. Section **2.6 Remote Control Applications** describes the 24-67 setup and line connections for numerous different remote control applications. Refer also to the 24-67 installation diagrams in the back of this manual.

2.2 Proper Grounding Practices

The surge protection diodes on the two wire audio lines, and the four wire audio lines protect the 24-67 from line transients. It is imperative that a good earth ground be used on the ground conductor screw terminal (J1) or a **SERIOUS SHOCK HAZARD** could develop if lightning were to strike the power line or the audio lines. In order to protect the operator to the highest possible degree, obtain a good earth ground for the ground conductor on the ground conductor screw terminal.

The surge protection diodes are of little value without this earth ground and **EXTREME CAUTION** must be observed when servicing the 24-67 in the presence of a local lightning storm. In addition, the internal circuits can be damaged when a good earth ground is not used and lightning strikes the power line or the audio lines.

2.3 Switch Settings

This section describes the function of the individual switches SW1, SW2 and SW3.

SW1: The 24-67 firmware upgrade process shall be initiated by pressing PCB switch SW1 during startup.

2.3 Switch Settings (cont.)

SW2: The 24-67 Test mode shall be entered by depressing PCB switch SW2. Test mode can also be entered by pressing the keypad button 1 and keypad button 3 during startup.

SW3: The 24-67 Microcontroller can be reset to startup by depressing PCB switch SW3.

2.4 Remote Control Applications

There are numerous remote control applications that can be provided by the 24-67. Each application requires a specific jumper configuration and specific line connections. Certain 24-67 options are also required for each application. The following is a description of each of the remote control applications.

Application 1 - Two wire, no supervisory, no alternate line: This application provides basic 2-wire operation. The base station is connected to J5 and additional parallel remotes are connected to J6.

Application 2 - Two wire with supervisory: This application provides 2-wire operation with supervisory control. The base station is connected to J6 and the parallel remotes under supervisory control are connected to J5.

Application 3 - Two wire with alternate line: This application provides 2-wire operation with alternate line selection. The primary line is connected to J5 and the alternate line is connected to J6.

Application 4 - Four wire, no supervisory, no alternate line: This application provides basic 4-wire operation. The base station is connected to J5 and additional parallel remotes are connected to J6.

Application 5 - Four wire with supervisory: This application provides 4-wire operation with supervisory control. The base station is connected to J6 and the parallel remotes under supervisory control are connected to J5.

Application 6 - Four wire with alternate line: This application provides 4-wire operation with alternate line selection. The primary line is connected to J5 and the alternate line is connected to J6.

Application 7 - Two wire with alternate line summed audio: This application provides 2-wire operation with alternate line selection. Audio from the alternate line is also summed with audio from the primary line. The primary line is connected to J5 and the alternate line is connected to J6.

Application 8 - Combined two wire and four wire (for use with 20-88): This application allows operation with an IDA 20-88 that is interfaced to both 2-wire and 4-wire lines. The selected line from the 20-88 is connected to J5. J6 is not used.

2.4 Remote Control Applications (cont.)

The following chart details the required jumper configuration for each remote control application.

	Application #							
	1	2	3	4	5	6	7	8
JP3	•	•		•	•			
JP4	•	•		•	•			
JP5	•			•				•
JP6	•			•				•
JP7				•	•			
JP8				•	•			
JP9				•				•
JP10				•				•
JP12							•	
JP13							•	
JP14							•	
JP15							•	

• - Jumper installed

Note: Jumper JP1, JP2, JP17, JP18 and JP19 should always be installed. Jumper JP16 is normally installed and the 4-wire transmit pair line impedance or the 2-wire line impedance is about 600 ohms. With JP16 removed the 4-wire transmit pair line impedance or the 2-wire line impedance is greater than 5k ohms. The 4-wire receive pair line impedance is always about 600 ohms. If there are several remotes in parallel on the system, it is recommended that all remotes except for one be in the high impedance state. This will minimize loading on the system.

The following diagrams detail the line connections required for each remote control application and can be used as an aid when installing, troubleshooting and/or configuring a 24-67.

2.4 Remote Control Applications (cont.)

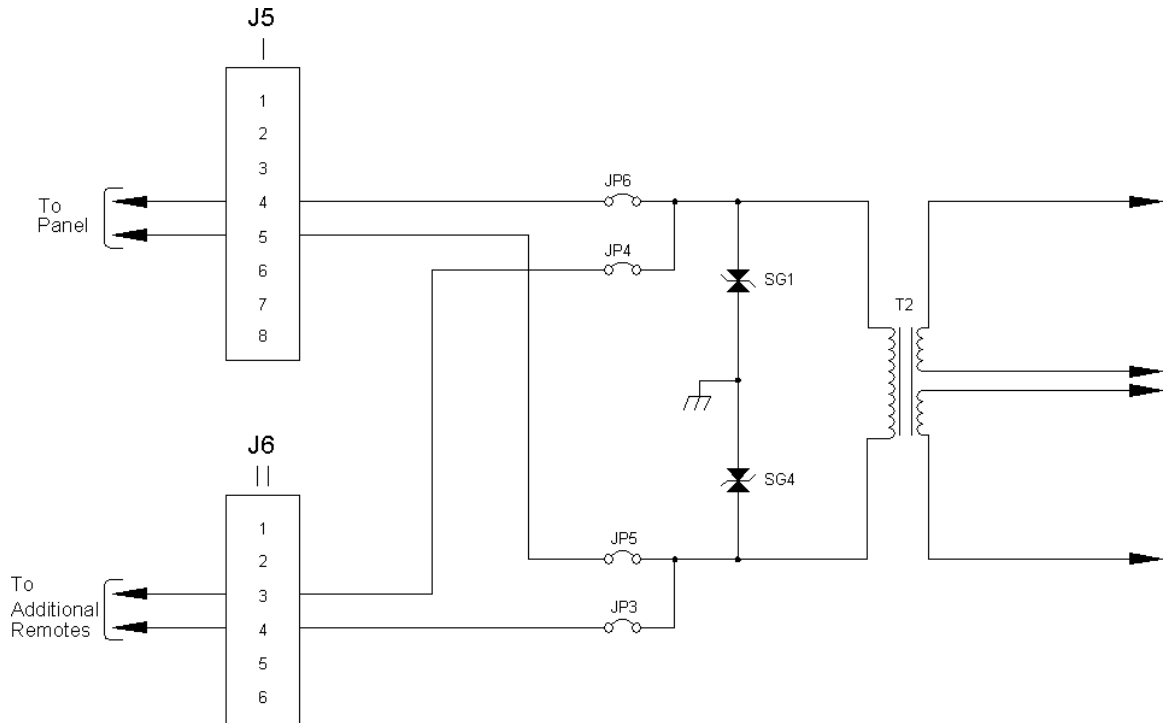

Application 1 - Two wire, no supervisory, no alternate line

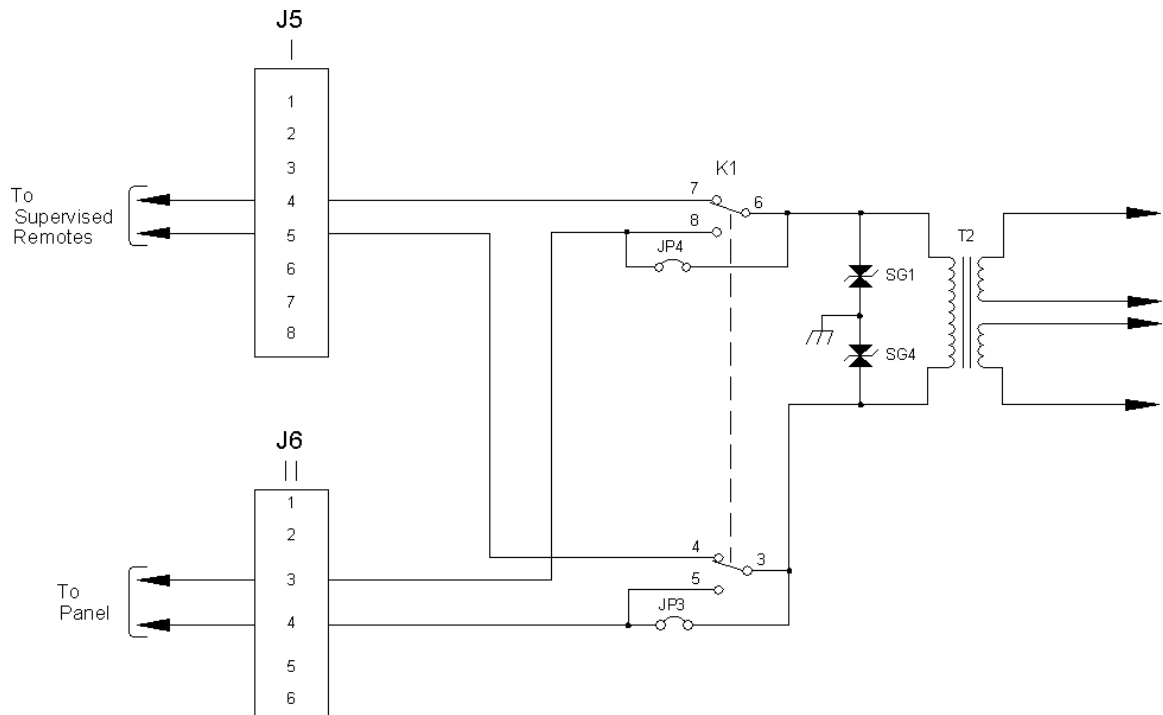

Application 2 - Two wire with supervisory

2.4 Remote Control Applications (cont.)

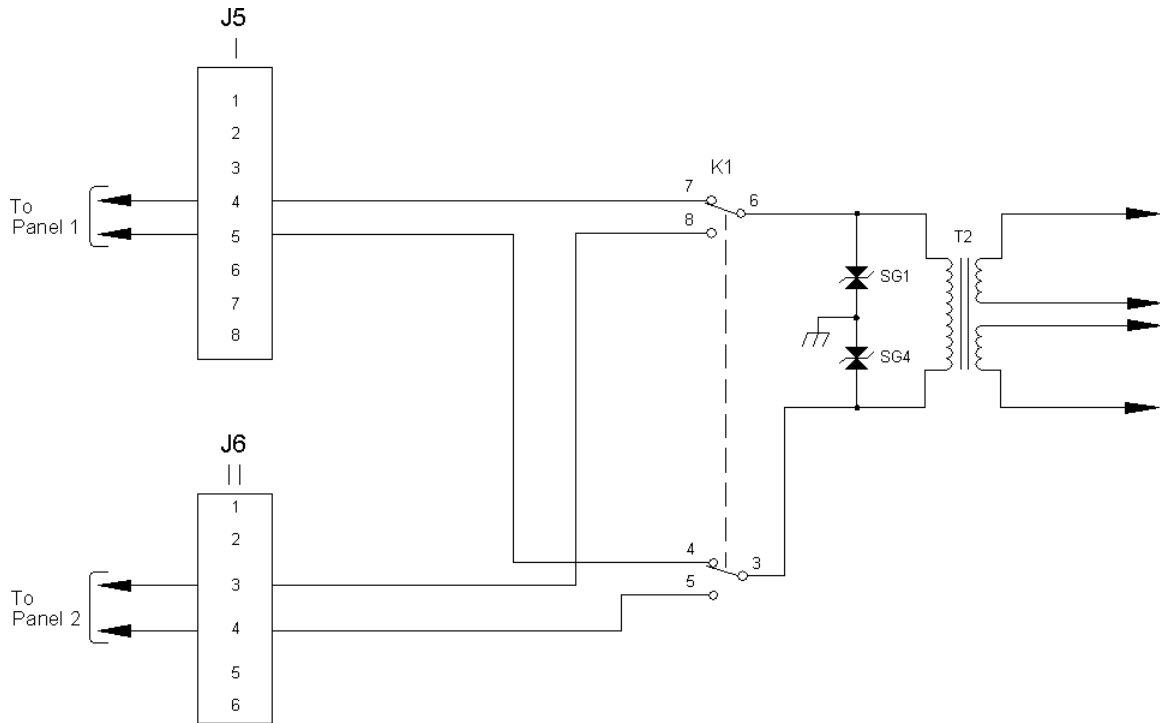

Application 3 - Two wire with alternate line

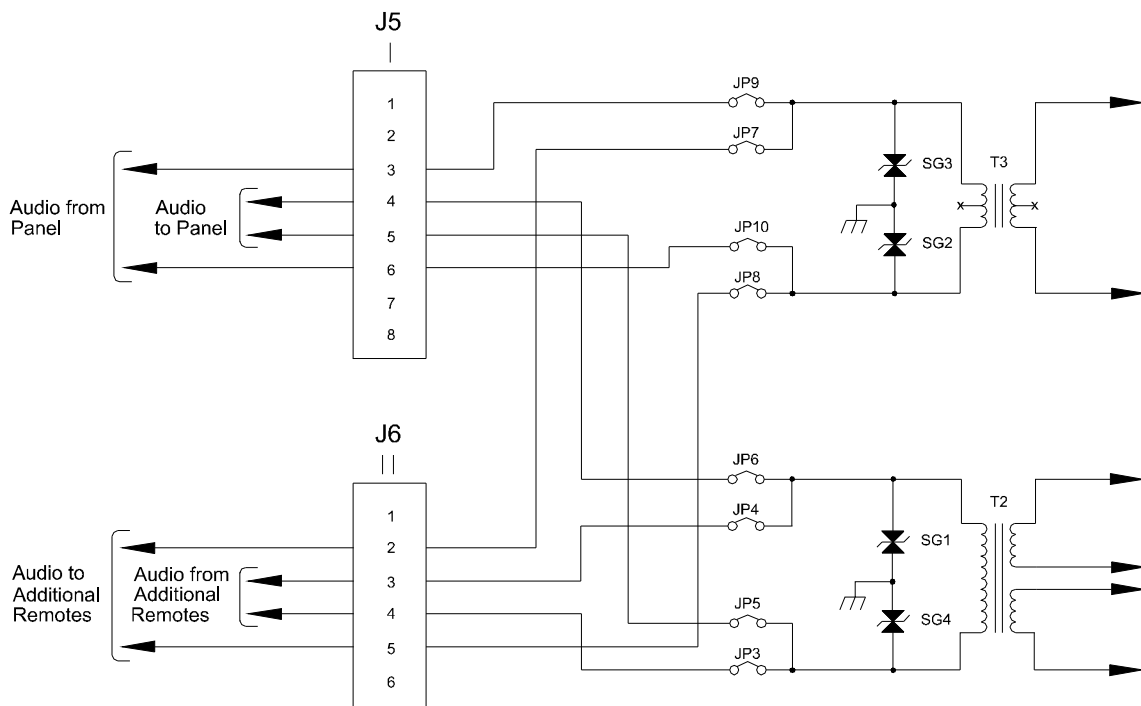

Application 4 - Four wire, no supervisory, no alternate line

2.4 Remote Control Applications (cont.)

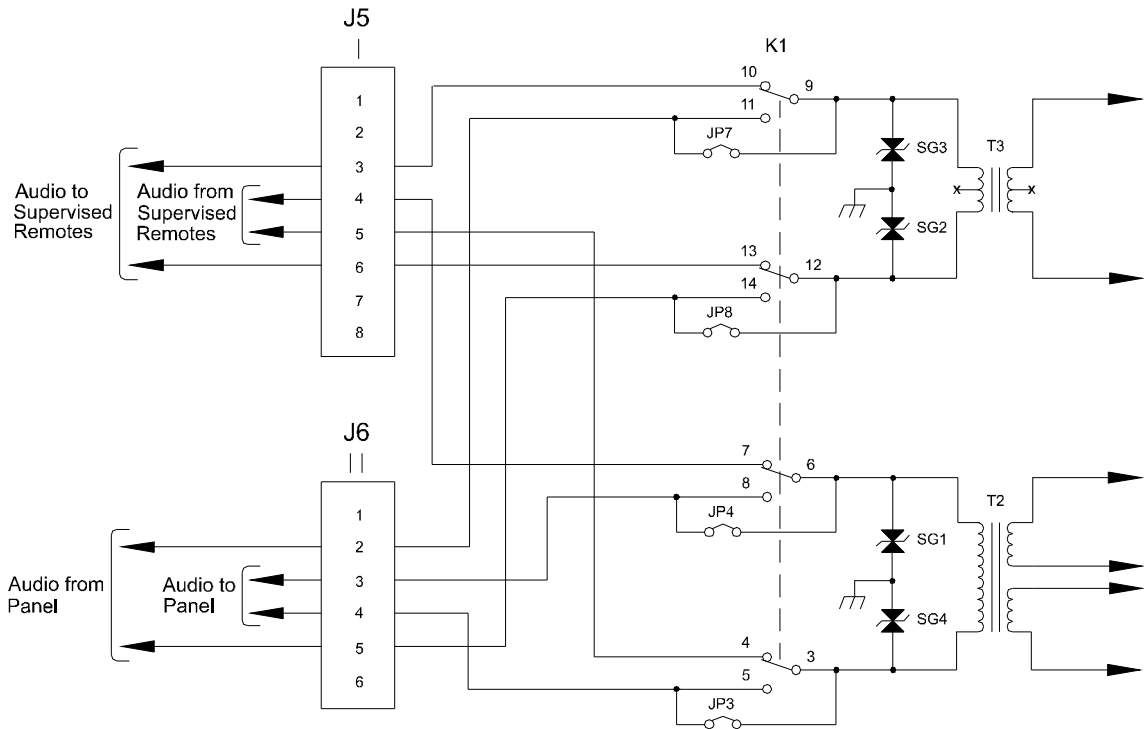

Application 5 - Four wire with supervisory

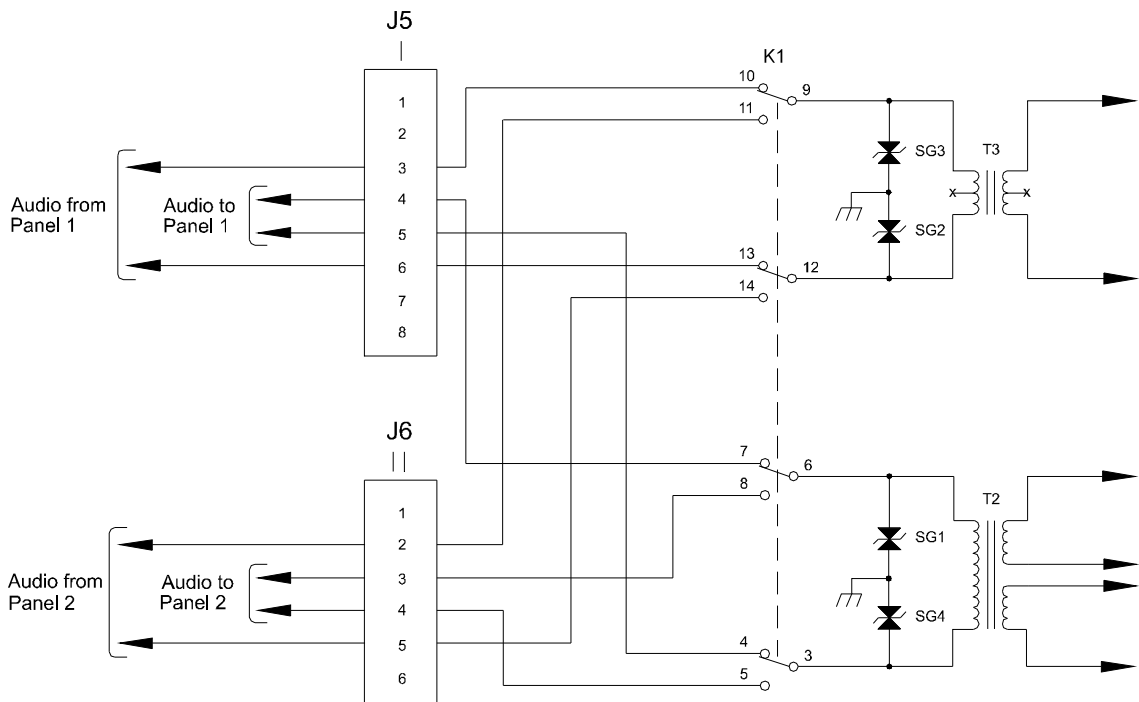

Application 6 - Four wire with alternate line

2.4 Remote Control Applications (cont.)

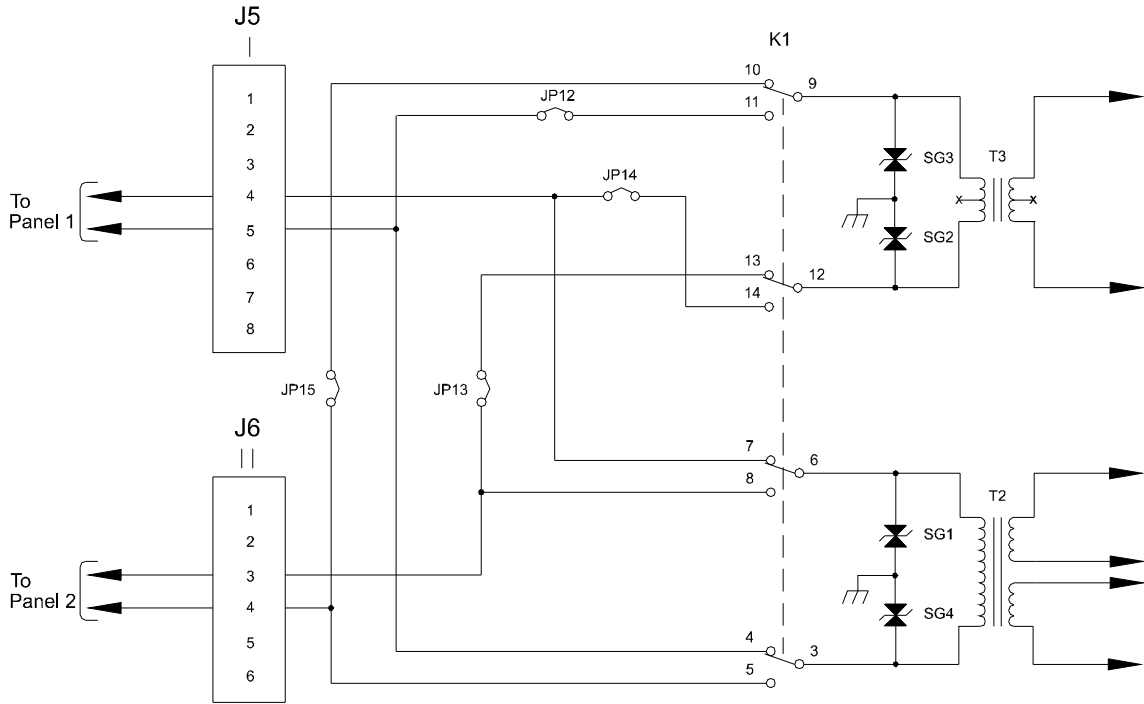

Application 7 - Two wire with alternate line summed audio

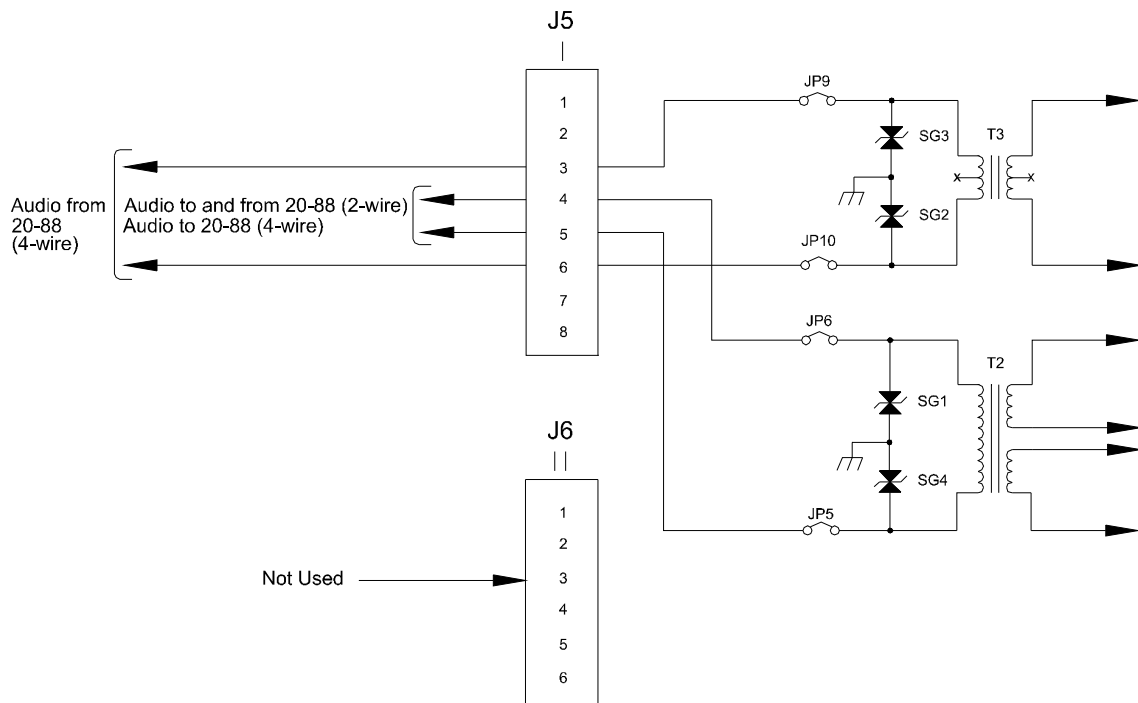

Application 8 - Combined two wire and four wire (for use with 20-88)

3.0 ADJUSTMENT PROCEDURES

The following will explain the adjustment procedure for all potentiometers and EPOTs in the 24-67. Most potentiometers and EPOTs are factory preset and will, in most cases, not need adjustment. The factory adjustment procedure and the recommended field adjustment procedure are given for most potentiometers and EPOTs. Refer to the programming and adjustment utility software application or Test mode for the complete adjustment procedure.

If your 24-67 has a LCD option you can also set these adjustments from the Test mode. Test mode shall be entered by depressing PCB switch SW2. Test mode can also be entered by pressing the keypad button 1 and keypad button 3 during startup. Refer to the Test mode appendix at the back of this manual for more information.

3.1 Microphone To Line Level

Factory adjustment procedure - With the handset or desk microphone removed, inject a 1 kHz tone at 1 Vrms from a 600 ohm generator into the microphone input J11-4. Place the 24-67 into intercom mode and begin transmitting by grounding J11-3. Connect a 600 ohm load to the output terminals J5-4 and J5-5. Adjust EPOT via programming and adjustment utility software application or Test mode so that 0 dBm (.77 Vrms) appears across the 600 ohm load.

Field adjustment procedure - While speaking into the handset or desk microphone, monitor the output of the base station or repeater transmitter with a service monitor or deviation meter and Adjust EPOT via programming and adjustment utility software application or Test mode for proper transmitter deviation.

3.2 Desk Microphone Output Sensitivity

The audio output level of the desk microphone can be adjusted through a hole in the bottom of the desk microphone. A small jeweler's flat blade screwdriver will be needed. The adjustment may need to be made depending upon background noise in the environment where the 24-67 is located and also upon the user of the desk microphone and how close and/or loud the user speaks.

3.3 Internal Microphone Level

Factory adjustment procedure - Microphone To Line Level EPOT should be set properly before making this adjustment. Inject a 1 kHz tone at 1 Vrms from a 600 ohm generator into the internal microphone input MK1 pin 1+ (right side of R156). Connect a 600 ohm load across the output terminals J5-4 and J5-5 and begin transmitting by holding down the internal microphone PTT button. Adjust EPOT via programming and adjustment utility software application or Test mode so that 0 dBm (0.77 Vrms) appears across the 600 ohm load.

Field adjustment procedure - The internal microphone level can be adjusted by speaking into the microphone, monitoring the output, and adjusting EPOT via programming and adjustment utility software application or Test mode to the desired level.

3.4 R28 and R39 - 2175 Hz Notch Filter Adjust

With the handset or desk microphone removed, inject a 2175 Hz tone at 1 Vrms into the microphone input J11-4. Begin transmitting by grounding J11-3 and adjust R28 and R39 for a minimum reading across the output terminals J5-4 and J5-5. Going back and forth between the two potentiometers will result in the best adjustment.

3.5 Tone Encode Level

Factory adjustment procedure - Remove the handset or desk microphone and begin transmitting by grounding J11-3. Install a 600 ohm load across the output terminals J5-4 and J5-5 and measure the AC voltage across it. The 24-67 will be generating a 2175 Hz hold tone across the load. Adjust EPOT via programming and adjustment utility software application or Test mode so that -20 dBm (.08 Vrms) is across the load.

Field adjustment procedure - Turn EPOT via programming and adjustment utility software application down so that the 24-67 will not key the base station or repeater panel. While keying the 24-67 several times, Adjust EPOT via programming and adjustment utility software application or Test mode until it keys the base station or repeater panel reliably.

3.6 MSK Encode Level (MSK Control Option is not available at this time)

Factory adjustment procedure - Put the 24-67 MSK remote into test mode and press any button until the MSK test tone is being sent to the line. Install a 600 ohm load across the line and Adjust EPOT via programming and adjustment utility software application or Test mode for 0 dBm (.77 Vrms) across the load.

Field adjustment procedure - If the panel does not decode updates sent by the 24-67 MSK remote, Adjust EPOT via programming and adjustment utility software application or Test mode until the panel decodes the updates reliably.

3.7 DTMF Encode Level

Factory adjustment procedure - Place the 24-67 into intercom mode. Connect a 600 ohm load to the output terminals J5-4 and J5-5. Adjust EPOT via programming and adjustment utility software application or Test mode so that 0 dBm (.77 Vrms) appears across the 600 ohm load.

Field adjustment procedure - While generating a DTMF tone from the keypad, monitor the output of the base station or repeater transmitter with a service monitor or deviation meter and Adjust EPOT via programming and adjustment utility software application or Test mode for proper transmitter deviation.

3.8 Receive Line Compensation

Factory adjustment procedure - For 2-wire or 4-wire applications, these EPOT adjustments are set to default values.

3.8 Receive Line Compensation (cont.)

Field adjustment procedure - These EPOT adjustments can be made via programming and adjustment utility software application or Test mode. This adjustment should normally not need to be adjusted in the field. However, if levels coming into the 24-67 are greater than +10 dBm (2.45 Vrms) or there is excessive line noise, this EPOT should be turned down.

3.9 Summed Audio Level

Factory adjustment procedure - Input a 1.5 kHz tone at 1 Vrms across J5-4 and J5-5 and input a 800 Hz tone at 1 Vrms across J6-3 and J6-4. Measure the output at TP1 and Adjust EPOT via programming and adjustment utility software application or Test mode so that the 800 Hz (alternate) signal is below the 1.5 kHz (primary) signal. When the alternate line button is depressed, the primary signal becomes the 800 Hz signal and the alternate signal becomes the 1.5 kHz signal. However, the alternate signal should remain below the primary signal.

Field adjustment procedure - When using the summed audio option, it may be necessary to adjust the alternate line audio. This can be done by adjusting EPOT via programming and adjustment utility software application or Test mode to the desired level.

3.10 Speaker Level

Factory adjustment procedure - Receive Line Compensation 2-wire and 4-wire EPOT's must be set properly before making this adjustment. With the volume control potentiometer R1 at maximum, Adjust EPOT via programming and adjustment utility software application or Test mode so that 3.45 Vrms appears across the speaker terminals while receiving a 1 kHz tone at +10 dBm (2.45 Vrms).

Field Adjustment procedure - While connected to the system and receiving audio from the highest level source, Adjust EPOT via programming and adjustment utility software application or Test mode so that audio in the speaker is a comfortable listening level. Do not turn it up too high since this will cause distortion and clipping. The audio should not exceed 3.45 Vrms at the speaker terminals.

3.11 Earpiece Level

Factory adjustment procedure - Receive Line Compensation 2-wire and 4-wire EPOT's must be set properly before making this adjustment. With a handset or a 150 ohm load connected from J11-2 to ground, Adjust EPOT via programming and adjustment utility software application or Test mode for 150 mV across the load while receiving a 1 kHz tone at +10 dBm (2.45 Vrms). The volume control potentiometer R1 should be set to maximum.

Field adjustment procedure - The earpiece and the base speaker are both controlled by the volume control potentiometer R1. It may be necessary in certain noisy environments to increase the level to the earpiece. While in the noisy environment and receiving audio from the source with the least level coming in, Adjust EPOT via programming and

3.11 Earpiece Level (cont.)

adjustment utility software application or Test mode for a comfortable listening level with the volume control potentiometer at maximum.

3.12 R29 and R40 - 2175 Hz Notch Filter Adjust

Factory adjustment procedure - Apply a 2175 Hz tone at +10 dBm (2.45 Vrms) across J5-4 and J5-5. Adjust R29 and R40 for a minimum reading across the speaker. Going back and forth between the two potentiometers will result in the best adjustment.

Field adjustment procedure - While receiving a 2175 Hz hold tone from a paralleled remote, adjust R29 and R40 until little or no hold tone is heard in the speaker. Going back and forth between the two potentiometers will result in the best adjustment.

3.13 R32 - Guard/Hold Tone Detect

Factory adjustment procedure - Apply a 2175 Hz tone at +10 dBm (2.45 Vrms) across J5-4 and J5-5. Adjust Detection Gain EPOT via programming and adjustment utility software application or Test mode half ways from the bottom setting. Adjust R32 for a maximum level at TP2 and then adjust Detection Gain EPOT via programming and adjustment utility software application or Test mode for 2.5 Vrms at TP2. Reduce input level by 20 dB (to 0.24 Vrms) and check that the DC level at U11A pin1 has changed from 0 Vdc to 3.3 Vdc. Reduce input level by a total of 50 dB (to .008 Vrms) and check that the DC level at U11B pin 7 has changed from 0 Vdc to 3.3 Vdc.

Field adjustment procedure - Adjust R32 as described in the factory adjustment procedure. Adjust Detection Gain EPOT via programming and adjustment utility software application or Test mode to the bottom setting. While a paralleled remote is being keyed several times, adjust Detection Gain EPOT via programming and adjustment utility software application or Test mode up until the TX indicator comes on and follows the paralleled remote. It is best to use the paralleled remote that is the furthest away from the unit being setup or, in other words, the paralleled remote that has the most line loss. Check to be sure that all other paralleled remotes will make the TX indicator illuminate.

4.0 CIRCUIT DESCRIPTION

4.1 Power Supply

Power is supplied to the 24-67 via the supplied 15VDC wall transformer. It is connected at J7 on the back of the 24-67. The polarity of the connector must be correct. From J7 the power is routed through a diode D11 and a 1 amp fuse F1. Diode D11 prevents a reverse polarity from harming the 24-67. Power is fed into voltage regulator U20. The output voltage of U20 is set to 12.5. This 12.5 Vdc through a diode D16 drives the audio section of the 24-67. It is also fed into voltage regulator U26, U27 and U38. The output voltage of U27 is set to 3.3 Vdc. The output voltage of U38 is set to 5 Vdc. The output voltage of U26 is set to 10 Vdc. It is also fed into voltage regulator U36. The output voltage of U36 is set to 5 Vdc REF. The 3.3 Vdc powers the digital section of the 24-67.

The 24-67 can be operated from a 13.8 Vdc supply through connector J2. Diode D17 prevents a reverse polarity from harming the 24-67.

4.2 Line Interface

The line is connected to the 24-67 through the two back panel modular jacks, J5 and J6. The 24-67 can be configured in several different configurations. It can be 2-wire or 4-wire, 2-wire or 4-wire with supervisory control, and 2-wire or 4-wire with alternate line. The lines are protected from transients by surge arresters SG1 - SG4.

4.3 Two Wire, No Supervisory, No Alternate Line

In the basic two wire configuration, the 2-wire line from the base station is connected to J5-4 and J5-5. Jumpers JP5 and JP6 are installed so that audio to and from the base station is routed through transformer T2. With jumpers JP3 and JP4 installed, additional remotes may be connected in parallel to J6-3 and J6-4. Receive audio is coupled through transformer T2 and passes from pin 4 of T2 through EPOT U8C to the buffer amplifier U10D. Transmit audio coming from pin 1 of U14 goes to pin 6 T2 and pin 1 of U21 goes to pin 7 T2 where it is coupled to the line.

4.4 Two Wire With Supervisory

In the two wire configuration with supervisory control, relay K1 is used for implementation of the supervisory mode. Only one user should have supervisor privileges. The 2-wire line from the base station is connected to J6-3 and J6-4. Additional remotes should be connected to J5-4 and J5-5. Jumpers JP3 and JP4 are installed so that audio to and from the base station is always routed through transformer T2. When the SUPER key is pressed, K1 is activated thus disconnecting any remotes connected to J5 from the line. Receive audio is coupled through transformer T2 and passes from pin 4 of T2 through EPOT U8C to the buffer amplifier U10D. Transmit audio coming from pin 1 of U14 goes to pin 6 T2 and pin 1 of U21 goes to pin 7 T2 where it is coupled to the line.

4.5 Two Wire With Alternate Line

In the two wire configuration with alternate line, relay K1 is used to select the alternate line. The 2-wire line from the primary base station is connected to J5-4 and J5-5. The 2-

4.5 Two Wire With Alternate Line (cont.)

wire line from the alternate base station is connected to J6-3 and J6-4. When the ALT key is pressed, K1 is activated thereby connecting the alternate line to transformer T2. Receive audio is coupled through transformer T2 and passes from pin 4 of T2 through EPOT U8C to the buffer amplifier U10D. Transmit audio coming from pin 1 of U14 goes to pin 6 T2 and pin 1 of U21 goes to pin 7 T2 where it is coupled to the line.

4.6 Four Wire, No Supervisory, No Alternate Line

In the basic four wire configuration, the 4-wire line from the base station is connected to J5. Audio from the base station comes in on J5-3 and J5-6 and is passed through jumpers JP9 and JP10 to transformer T3. The audio is coupled through transformer T3 and passes from pin 6 of T3 through EPOT U8B to the buffer amplifier U10D. Transmit audio coming from pin 1 of U14 goes to pin 6 T2 and pin 1 of U21 goes to pin 7 of transformer T2. The audio is coupled through transformer T2 and passes through jumpers JP5 and JP6. The audio is then passed to the base station through J5-4 and J5-5.

Additional remotes may be connected in parallel to J6. Jumpers JP7 and JP8 pass audio from the base station to the parallel remotes through J6-2 and J6-5. Jumpers JP3 and JP4 pass audio from the parallel remotes to the base station through J6-3 and J6-4.

4.7 Four Wire With Supervisory

In the four wire configuration with supervisory control, relay K1 is used for implementation of the supervisory mode. Only one user should have supervisor privileges. The 4-wire line from the base station is connected to J6 with J6-2 and J6-5 used for audio from the base station and J6-3 and J6-4 used for audio to the base station. Additional remotes should be connected in parallel to J5 with J5-3 and J5-6 used for audio from the base station to the parallel remotes and J5-4 and J5-5 used for audio from the parallel remotes to the base station. When the SUPER key is pressed, K1 is activated thus disconnecting any remotes connected to J5 from the line. Jumpers JP7 and JP8 allow audio from the base station to always be coupled through transformer T3 and where it then passes from pin 6 of T3 through EPOT U8B to the buffer amplifier U10D. Transmit audio coming from pin 1 of U14 goes to pin 6 T2 and pin 1 of U21 goes to pin 7 of transformer T2. Jumpers JP3 and JP4 are installed so that audio coupled through transformer T2 is always passed to the base station.

4.8 Four Wire With Alternate Line

In the four wire configuration with alternate line, relay K1 is used to select the alternate line. The 4-wire line from the primary base station is connected to J5 with J5-3 and J5-6 used for audio from the base station and J5-4 and J5-5 used for audio to the base station. The 4-wire line from the alternate base station is connected to J6 with J6-2 and J6-5 used for audio from the base station and J6-3 and J6-4 used for audio to the base station. When the ALT key is pressed, K1 is activated thereby connecting the alternate line to transformers T2 and T3. Audio from the base station is coupled through transformer T3 and passes from pin 6 of T3 through EPOT U8B to the buffer amplifier U10D. Transmit audio coming from pin 1 of U14 goes to pin 6 T2 and pin 1 of U21 goes

4.8 Four Wire With Alternate Line (cont.)

to pin 7 of transformer T2. The audio is coupled through transformer T2 and is then passed to the base station.

4.9 Two Wire With Alternate Line Summed Audio

In the two wire configuration with alternate line and summed audio, relay K1 is used to select the alternate line. The 2-wire line from the primary base station is connected to J5-4 and J5-5. The 2-wire line from the alternate base station is connected to J6-3 and J6-4. When the alternate line is not selected, the primary line is connected to transformer T2 and the alternate line is connected to transformer T3 through jumpers JP13 and JP15. When the ALT key is pressed, K1 is activated thereby selecting the alternate line and connecting it to transformer T2. The primary line is then connected to transformer T3 through jumpers JP12 and JP14. Receive audio from the selected line is coupled through transformer T2 and passes from pin 4 of T2 through EPOT U8C to the buffer amplifier U10D where it is summed with audio coupled through transformer T3 and passes from pin 6 of T3 through EPOT U8B from the unselected line. EPOT U8B is used to control the level of audio received from the unselected line. Transmit audio coming from pin 1 of U14 goes to pin 6 T2 and pin 1 of U21 goes to pin 7 of transformer T2 where it is coupled to the selected line.

4.10 Combined Two Wire and Four Wire (for use with 20-88)

The 24-67 can be used with an IDA 20-88 to allow the 24-67 to control multiple base stations. The lines from the base stations are connected to the 20-88 which selects one of the lines and passes that line to the 24-67. This configuration allows both 2-wire and 4-wire lines to be connected to the 20-88 at the same time. The selected line from the 20-88 is connected to J5. J6 is not used. Jumpers JP5 and JP6 connect J5-4 and J5-5 to transformer T2 which couples transmit audio coming from pin 1 of U14 goes to pin 6 T2 and pin 1 of U21 goes to pin 7 T2 where it is coupled to the line for both 2-wire and 4-wire lines. Receive audio is also coupled through transformer T2 for 2-wire lines and passed to the buffer amplifier U10D. Jumpers JP9 and JP10 connect J5-3 and J5-6 to transformer T3. Receive audio from 4-wire lines is coupled through transformer T3 and passed to the buffer amplifier U10D. EPOT U8B is used to control the level of audio received from 4-wire lines and should be adjusted so that audio received from the 4-wire lines is at the same level as audio received from the 2-wire lines.

4.11 Receive Audio

Receive audio from the summing amplifier U10D in the line interface section is passed to the receive audio buffer amplifier U5A. The audio then goes to an automatic gain control (AGC) circuit. The AGC circuit provides for a constant output voltage over an input range of 30 dB. The AGC circuit is comprised of U15B and U5D and their associated components. The AGC output is at pin 14 of U5D. The audio input on pin 13 of U15B is rectified internally and is used to control the gain of the internal gain cell that is connected between pin 11 and pin 9 of U15B. The attack time of the AGC is determined by C156 and the recovery time is determined by C62.

From pin 14 of U5D the audio signal goes to pin 14 of audio gate U16B. This gate is normally enabled unless the AGC bypass has been enabled. If the AGC bypass circuit

4.11 Receive Audio (cont.)

has been enabled, this gate will be disabled and audio will be routed to the notch filter from pin 3 of audio gate U16A instead of pin 15 of audio gate U16B.

The notch filter is comprised of U5B and U5C and their associated components. Potentiometers R29 and R40 are used to tune the notch filter to 2175 Hz. The notch filter removes the 2175 Hz hold tone from the line audio to prevent it from being heard.

From the notch filter circuit pin 8 of U5C, the audio goes to the summing amplifier U4B. The line audio from the summing amplifier U4B is amplified by U1C and then passed to the volume control potentiometer R1. D1 and D2 are used to help protect the 24-67 from electrostatic discharges. Resistor R3 prevents the audio from being turned completely off. From the volume control potentiometer, the audio goes to the headset earpiece level adjustment EPOT U8D and the handset earpiece level adjustment EPOT U13D. The audio is then fed from EPOT U8D to the headset earpiece driver U4A, also from EPOT U13D to the handset earpiece driver U6B. The output of U6B is passed to the earpiece enable gate U16D. If the 24-67 is equipped with a handset, this gate allows the audio to go to the earpiece in the handset. If the 24-67 is equipped with a desk microphone, the earpiece enable gate will be disabled. This allows pin 2 on J11 to be used as the monitor line from the desk microphone

From the volume control potentiometer, the audio also passes to the speaker level adjustment EPOT U8A then to the speaker driver preamp circuit. The preamp circuit is comprised of U1A and U1B and their associated components. The preamp output is at pin 1 of U1A and pin 7 of U1B. The audio is then fed into the speaker driver U3. U3 and its associated circuitry is stereo audio power amplifier that contains two identical amplifiers capable of delivering 6 Watts per channel of continuous average power into a 4 ohm load. The gain of each channel is fixed at 20 dB. The A output, U3 pins 7 and 8 of the speaker driver goes to J8, the internal speaker connector. The B output, U3 pins 13 and 14 of the speaker driver goes to J18, the external speaker connector.

4.12 Transmit Audio

Microphone audio from the handset or the desk microphone comes from pin 4 of J11. The microphone is biased by resistors R11 and R22. The microphone audio then passes through an electrostatic discharge protection circuit consisting of D3 and D4. The audio is then compressed by the compression circuit consisting of U15A and U6C and their associated components. The compression circuit output is at pin 8 of U6C. The audio signal fed back from pin 8 of U6C to pin 3 of U15A is rectified internally and controls the gain of the internal gain cell that is connected between pin 5 and pin 7 of U15A. The attack time is determined by C150 and the recovery time is determined by C58.

From pin 8 of U6C the signal goes to the 2175 Hz notch filter consisting of U10B and U10C and their associated components. Potentiometers R28 and R39 are used to tune the notch filter to 2175 Hz. This filter notches out any 2175 Hz component that is present in the microphone audio. The notch depth is greater than 45 dB. This helps prevent a user's voice from falsing any 2175 Hz detectors that are in a panel or another parallel remote.

4.12 Transmit Audio (cont.)

The microphone audio then passes through the microphone EPOT U9C. This EPOT allows muting of the microphone audio when necessary to eliminate any audio feedback ringing. This EPOT U9C is also the transmit audio adjustment potentiometer.

U10A is a summing amplifier that sums the transmit audio, the function tones and the DTMF tones. The function tones are generated by the Audio Signaling Processor U19 and its associated components. EPOT U9B is used to adjust the level of the function tones. The DTMF tones are generated by the DTMF Transceiver U24 and its associated components. EPOT U9D is used to adjust the level of the DTMF tones. The output of U10A goes to the line driver U14 and U21 which drives the line coupling transformer T2. Jumper JP16 is used to change the 4-wire transmit pair line impedance or the 2-wire line impedance from about 600 ohms when JP16 is on to greater than 5k ohms when JP16 is off.

4.13 Digital Control Section

The 24-67 is controlled by U41 which is a 16-bit Microcontroller. This microcontroller incorporates serial communication UART and I²C. This microcontroller also incorporates general purpose I/O ports and a parallel data communication port. The control program for U41 is stored in the internal 128KB Flash memory.

Other inputs to U41 are the monitor line from a desk microphone, external PTT from the foot switch connector, local PTT from the handset or desk microphone and encode PTT from the internal encode/decode connector. Outputs from U41 are four I/O lines that go to the keypad board interface controller U39 to allow U41 to control the display LEDs and the LCD. Other outputs from U41 are the DTMF, MSK, and Tone internal speaker enable which enables audio from these sources to the internal speaker.

U42 is a CPU low voltage reset IC that functions as a manual reset and low voltage reset for U41. This causes pin 1 of U42 to stay low. Pin 1 of U42 is also low whenever the 3.3 Vdc power supply is below 2.7 Vdc. This ensures that U41 is properly reset on power-up.

All of the programmable operating characteristics of the 24-67 are stored in U40 which is a serial EEPROM. The data on pin 5 of U40 is read from or written into U18 by the clock signal on pin 6 of U40. The data in U40 is checked on power-up to determine if it has been corrupted. If the data in U40 has been corrupted, an error indication will be given on the front panel display. The data stored in U40 is changed by using the programming cable and the programming software supplied by IDA.

4.13 Digital Control Section (cont.)

U31 is an 8-bit output latch that is used to control various audio gates and one relay. Three of the outputs are connected to open collector transistors Q1, Q4 and Q5. These three outputs are used to mute the speaker audio, enable the line driver and control the supervisory/alternate line relay K1. Another two of the outputs are connected to audio gates in U7. These two outputs are used to enable encode audio from the internal encode/decode connector J13 and microphone audio from the headset connector J14.

U18 is an 8-bit microcontroller. Data written to it by U41 controls the Signaling Processor U19. U19 is used to generate the tones required by the 24-67 including the guard tone, hold tone, function tones, alert tone and various other tones. U19 also decodes function tone sequences from the line and reports them to U18.

J10 is the connection to the keypad board. There are two power pins, 5 Vdc and 13.8 Vdc, and a ground pin. There are four row outputs to the keypad matrix and three column inputs from the keypad matrix. There are the four I/O lines for controlling the display LEDs and the LCD. There is also the analog VU signal for the VU meter on the display.

4.14 MSK Interface (MSK Control Option is not available at this time)

U25 is an MSK modem and is used to encode and decode the MSK data. Crystal Y3 provides a 4 MHz clock to U25. The output of the AGC circuit is fed to pin 3 of U25 which will decode MSK data from this audio. The decoded data is then read from U25 by the microprocessor. Data to be transmitted is written to U25 by the microprocessor. U25 converts this data to MSK tones which then appear on pin 2 of U25. The MSK tones pass through to the summing amplifier U10A. EPOT U9A is used to adjust the level to control the gain of the MSK tones through the summing amplifier. The MSK tones are then passed to the line driver and on to the line.

4.15 Parallel Detect

Line audio enters the parallel detect circuit through pin 1 of U5 and is passed into the 2175 Hz bandpass filter through EPOT U13A. EPOT U13A adjusts the level of audio into the bandpass filter and therefore into the guard and hold tone detect circuits. The bandpass filter is comprised of U12A, U12B, and U12C and their associated components. Potentiometer R32 is used to tune the bandpass filter to 2175 Hz.

The 2175 Hz tones that come out of the bandpass filter are passed into the guard and hold tone detect circuits. For the guard tone detect circuit, audio passes through C171 to diodes D9. These diodes pass only the positive transitions of the 2175 Hz tones to capacitor C63 which causes C63 to charge up. During negative transitions, C63 is discharged through resistor R114. Pin 1 of U11A will be turned on when the charge on C63 is greater than the voltage on pin 2 of U11A. When pin 1 of U11A is on, pin 1 will be pulled high which indicates that guard tone is being detected.

For the hold tone detect circuit, audio is passed to amplifier U12D which provides approximately 30 dB of gain. Diodes D10 pass only the positive transitions of the 2175 Hz tones to capacitor C172 which causes C1 to charge up. During negative transitions, C1 is discharged through resistor R115. Pin 7 of U11B will be turned on when the charge on C172 is greater than the voltage on pin 6 of U11B. When pin 7 of U11A is on, pin 7 will be pulled high which indicates that hold tone is being detected.

4.16 Keypad Board

The keypad board is mounted on the faceplate of the 24-67. It is connected to J10 on the base board by a ribbon cable that is soldered to J5 on the keypad board. The keypad board has the contacts for the front panel buttons etched on it, and provides a backplane for the front panel buttons. The rows and columns of the keypad are fed to the baseboard through connector J5. The microprocessor determines if a certain key is pressed by pulling the row input for that key low and then checking to see if the column output for that key also goes low.

LEDs are provided for each button and also for the TX indicator. These LEDs are driven by the LED display driver U1 which also drives the single digit 7-segment LED display D1 when D1 is installed. This driver has a serial interface to the microprocessor on the base board. Serial data coming from the baseboard on pin 1 is clocked into U1 by the clock signal on pin 13. When all the data is clocked in, pin 12 is pulsed to load the data into the drivers.

4.16 Keypad Board (cont.)

Also located on the keypad board are the mounting sockets for the clock, VU meter, and LCD options. The clock option plugs into J4 and the LCD option plugs into J3. The VU meter option plugs into either J1 or J2 depending on if the LCD option is installed.

4.17 Clock Option

The clock option plugs into J4 on the keypad board. It consists of a four digit 7-segment LED clock display module that is connected through J4 to the LED display driver U1 on the keypad board. This option is used to display the time of day and in some configurations is also used to display the frequency, channel, or system and group selected.

4.18 VU Meter Option

The VU meter option plugs into J1 on the keypad board when the LCD option is installed and into J2 when the LCD option is not installed. This option converts a DC signal level on pin 6 of J1 or J2 to a readout on an LED bar graph. This DC signal comes from the base board through the keypad board.

On the base board the transmit signal is fed to an amplifier consisting of U11A and its associated components. The output of the amplifier is then fed to a rectifier circuit consisting of C66, D11, D12, and C67. The resulting DC signal is then passed through a resistor divider network of R83 and R84 before being sent to the keypad board and the VU meter option board.

4.19 LCD Option

The LCD option includes a 32 character (two line) LCD module which plugs into J3 on the keypad board. Serial data from the microprocessor is transmitted to U2 on the keypad board which is an 8-bit serial input, parallel output latch. Serial data coming in on pin 14 is clocked into U2 by the clock signal on pin 11. Once all 8 bits have been clocked in, data is transferred to the LCD (pins 7 - 14 of J3) by a rising edge on pin 12 of U2. The contrast level of the LCD is adjusted using potentiometer R8 on the keypad board.

4.20 Programming Cable

The programming cable is used for programming the desired configuration into the 24-67. One end of the cable is an eight position modular connector that plugs into J5 on the 24-67. The other end is a DB-25 connector that connects to the serial port of the computer. Inside the housing of the DB-25 connector is a TTL to RS-232 converter. Four wires are used between the 24-67 and the converter. These are 5 Vdc, ground, RX data, and TX data. There are only three connections between the converter and the computer. These are ground, RX data, and TX data. If the computer has a DB-9 serial port, the DB-25 to DB-9 adapter will need to be used.

4.21 Proper Grounding

The following grounding methods must be followed for proper lightning protection. External lightning protection is preferred or an earth ground wire must be attached to the earth ground post (J1) in the 24-67 as shown in the following diagram:

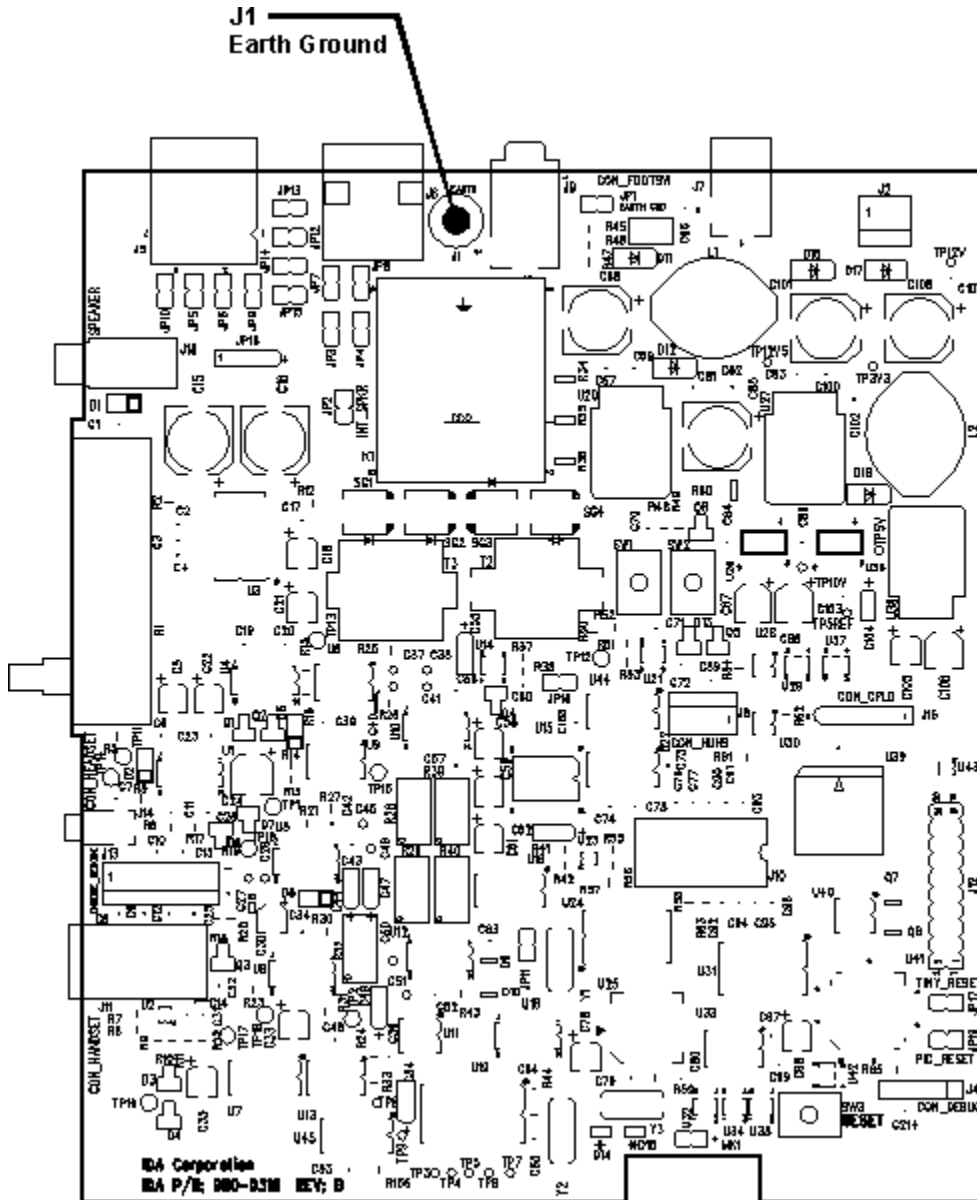

Proper Grounding (cont.)

On the 24-67 base cabinet, a hole needs to be made to allow the earth ground wire to exit the cabinet and be connected to an earth ground such as a water pipe or other suitable connection. Drill hole only through the plastic cabinet. Drill hole size will be determined by the gauge of wire used for the earth ground. 14awg (or heavier) stranded wire is recommended. Below is a diagram which shows the suggested hole location.

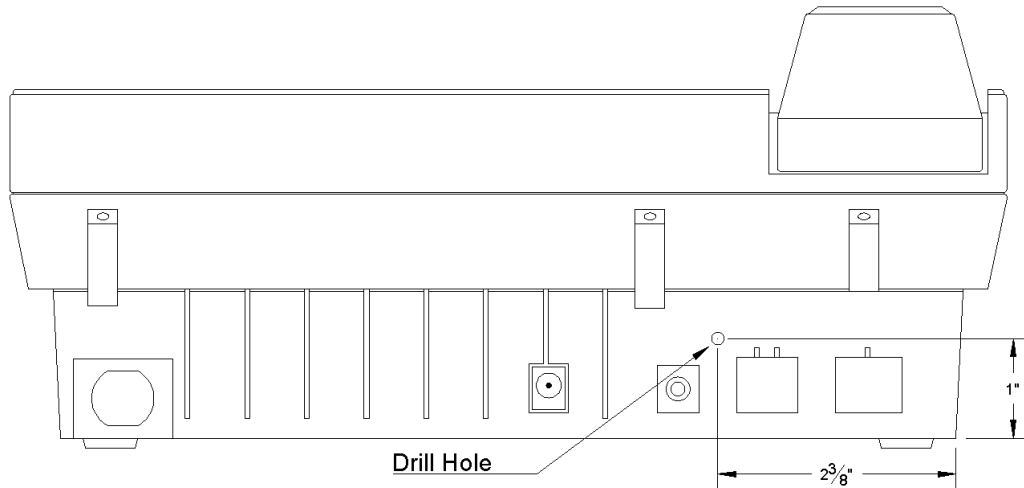

24-67 Remote Base Controller
(Rear View)

5.0 TROUBLESHOOTING

5.1 Microphone Audio Doesn't Reach the Line

1. The Push-to-Talk (PTT) button should be depressed fully so that the TX indicator is on. If the TX indicator does not turn on, check the handset or desk microphone cord and connector. Note: The Tx indicator will not turn on during intercom.
2. Check to see if pin 5 of U2 goes low (0.7 Vdc or lower) when the PTT switch is depressed. If it does go low and there is still no microphone audio, U2 may be faulty. Replace it with a known working part.
3. The output of the compressor circuit, U6-8, should be biased at 5.0 Vdc with the microphone audio riding on it.
4. The output of the 2175 Hz notch filter circuit, U10-7, should be biased at 5.0 Vdc with the microphone audio riding on it.
5. The output of the summing amplifier, U10-1, should be biased at 5.0 Vdc with the microphone audio riding on it. If not, U10 may be faulty or the TX ADJ EPOT may be turned down too far.
6. The output of the line driver stage, U14-1 and U21-1, should be biased at 6.0 Vdc with the microphone audio riding on it. The line driver is turned on and off by the level present on U14-5 and U21-5. This level should be high (11.0 Vdc or more) when depressing PTT.

5.2 VU Meter Doesn't Function

1. This is a hardware option. Make sure the unit is equipped with it. If no audio appears on the line, refer to section 5.1.
2. Audio is amplified and buffered to the VU meter through U1. The output, U1-14, should be biased at 5.0 Vdc with microphone audio riding on it.
3. If VU audio is present on J10-9, the ribbon cable should be checked for an open.

5.3 Control/Alert Tones Do Not Reach the Line

1. All control tones and the alert tones are generated by the microprocessor through the Audio Signaling Processor U19 and its associated components. The tones will be present on U19 pin 20 during times when tones are generated. If not, replace U19 or refer section 5.12.
2. The control tones and the alert tones are fed from the Audio Signaling Processor to EPOT U9B. The input of EPOT U9B is pin 23, and should have tone(s) present during times when tones are being generated.
3. The tones pass through the tone adjust potentiometer EPOT U9B. Check the adjustment to see if it is set properly. If tones are still not being sent to the line, turn the potentiometer to maximum setting. If tones are present on the wiper arm of EPOT U9B pin 22 and they are still not reaching the line, then the problem is either in the summing amplifier stage U10A or the line driver stage U14 and U21. If so, refer to section 5.1 since microphone audio is probably not reaching the line either.

5.4 Control Tones Have No Effect on the Panel

1. See adjustment procedure for the proper setting of the tone levels.
2. Make sure the 24-67 configuration has been programmed to match what is expected by the panel.

5.5 Line Audio Doesn't Reach the Speaker

1. If a handset is being used, make sure the handset is properly seated in the cradle. Check the operation of the HUHS (Hang Up Hook Switch) by monitoring J8-2 with a DC voltmeter. If a desk microphone is being used, the speaker will remain on continually.
2. If the alternate line or supervisory option is installed make sure the line is connected to the appropriate modular receptacle and that the supervisory function is not selected. Also verify that the appropriate jumpers are installed or not installed.
3. While sending audio into the 24-67 from the line, monitor U5-14. This pin should be biased at 5.0 Vdc with the audio riding on it. If not, make sure the RX ADJ EPOT is set properly. If there is still no audio present on U5-14, U5 or U15 may be faulty.
4. Make sure audio will pass from U16-14 to U16-15 or from U16-2 to U16-3 when bypassing the AGC circuit. With the mute function off, the control pins on one of these audio gates should be high (5.0 Vdc present on U16-16 or U16-1).

5.5 Line Audio Doesn't Reach the Speaker (cont.)

6. While receiving audio from the line, U4-7 should be biased at 5.0 Vdc with the audio riding on it.
7. Check to be sure audio passes through the volume control potentiometer R1. After the volume control the audio should be on U1-1. In the speaker path U3-17 should be high (11.0 Vdc or more) and audio should be present at U3 pins 7 and 8.
8. The speaker level adjustment EPOT should be checked to see if it is properly set. U3 is the speaker driver and should have audio present on its output, pins 7 and 8. As a last step make sure JP2 is installed and the speaker connector is mated to J8.

5.6 Earpiece Audio is Not Loud Enough or No Sound

The following solutions assume that the speaker audio is working properly.

1. Check the earpiece level adjustment EPOT for proper adjustment.
2. The output of the earpiece amplifier, U6-7, should be biased at 5.0 Vdc with audio riding on it.
3. Earpiece audio should pass from U16-6 to U16-7 while U16-8 is low (0.7 Vdc or less). At J11-2 there should be approximately 150 mVrms of audio with the handset plugged in.
4. U16-9 should be high (5.0 Vdc) when the 24-67 is configured for a handset. If it is low (0.7 Vdc or less), the 24-67 is configured for a desk microphone and will need to be reconfigured by using the programming software.

5.7 A Constant Hum is Present in the Speaker

1. Check the filter capacitors and voltage regulators in the power supply section. Look for AC ripple riding on the DC voltages.
2. One or more audio adjustments may be turned up too high. Check all applicable adjustments according to the adjustment procedure.

5.8 Background Tone (2175 Hz) Present in Receive Audio

1. Check the 2175 Hz notch filter to see if it is set properly.
2. The 2175 Hz tone may be coming in at too high of a level. Check the levels coming from other parallel remotes.

5.9 Parallel TX Indicator Intermittent or Stuck On

1. The 2175 Hz hold tone arriving at the 24-67 is at too high of a level or the detection gain EPOT is set improperly.

5.10 One or More Keys Stuck On or Off

1. Unplug the 24-67 and then plug it back in.
2. Check the ribbon cable between the keypad board and the base board.
3. Microprocessor may be functioning improperly. Refer to section 5.12.

5.11 Faceplate Keys and All LEDs Inoperative

1. Unplug the 24-67 and then plug it back in.
2. Check the ribbon cable between the keypad board and the base board.
3. Microprocessor may be functioning improperly. Refer to section 5.12.

5.12 Microprocessor Functioning Improperly

1. Check for 3.3 Vdc on pins 10, 19, 26 and 38 on the microprocessor (U15).
2. Make sure JP17 and JP19 installed at all times.

5.13 Status Messages

The display on the 24-67 is used for displaying the selected frequency, channel, or system and group information. In addition, different status messages are also displayed. The appearance of the different status messages varies depending upon if the 24-67 has the Tone Control option or the MSK Control option and upon the type of display being used (either an LED or an LCD display). Each of the status messages are described below.

24-67 Tone Remote

32 character LCD	LED	Description
"DISABLED"	"d"	This message is displayed when the current channel is disabled and the Display Configuration Setting "Show Disabled Channels?" is not enabled.
"PROGRAMMING"	"P"	This is displayed while the 24-67 Tone remote is being programmed.
"*** ERROR ***" "NV MEMORY"	"E"	This initialization error is displayed if an error is detected communicating with non-volatile memory or if any of the configuration parameters were set to default during initialization. The 24-67 Remote will automatically reset after displaying this error.
"*** ERROR ***" "I2C POTS"	"E"	This initialization error is displayed if an error is detected communicating with the ePots. The 24-67 Remote will automatically reset after displaying this error. Automatically reset after displaying this error.
"*** ERROR ***" "INPUTS / OUTPUTS"	"E"	This initialization error is displayed if an error is detected while initializing the inputs and outputs. The 24-67 Remote will automatically reset after displaying this error.
"*** ERROR ***" "TONE PROCESSOR"	"E"	This initialization error is displayed if an error is detected communicating with the tone processor. The 24-67 Remote will automatically reset after displaying this error.
"*** ERROR ***" "TONE RESET"	"E"	This initialization error is displayed if an error is detected resetting the tone processor. Check that JP17 is installed.
"*** ERROR ***" "NO CHANS ENABLED"	"E"	This initialization error is displayed if all channels are disabled.

5.14 Status Messages (cont.)

24-67 TONE Remote

32 character LCD	LED	Description
“*** ERROR ***” “DISPLAY”	"E"	This initialization error is displayed if an error is detected initializing the display module. The 24-67 Remote will automatically reset after displaying this error.
“*** ERROR ***” “INITIALIZING”	"E"	This a general initialization error not covered by the previous enumerations.
“*** ERROR ***” “PTT TIME EXPIRED”	"E"	This run-time error is displayed when the maximum PTT time has elapsed during a PTT function. The error is cleared when all PTT inputs are cleared.
“*** ERROR ***” “CHANNEL DISABLED”	"E"	This run-time error is displayed when a PTT is attempted on a disabled channel.
“*** ERROR ***” “LINE NOT IDLE”	"E"	This run-time error is displayed when a PTT is attempted when a parallel transmission is detected and the Global Setting "Parallel override" is not enabled.
“*** ERROR ***” “PTT PROCESSING”	"E"	This run-time error is displayed when an error occurs during the PTT process.
N/A	"-"	Channel too high for 8-segment display to show properly.

PARTS LIST

24-67 Base Board 101-2467PRT1

Item	Reference	Description	Part No.	Qty.
1	C1,2,3,17,34,39,52, 63,69,71,72,74,75,82, 84,86,97,99,100,103, 107,109,110,113,114, 115,116,117,118,119, 120,122,124,126,127, 128,129,131,134,136, 140,142,143,144,146, 147,148,153,154,155, 156,158,159,160,161, 164,165,166,168,169, 171,173,175,177,180, 181,182,183,184,192, 193,194,195,197,201, 202,203,205,206,207, 208,209,211,214,215, 216,218,219	.1uF 16V X7R CAP	375-2104	88
2	C4,7,8,9,10,12,13,14, 27,31,32,66,70,76,77, 89,90,91,92,93,94,95, 96,111,112,121,123, 125,130,133,135,145, 157,162,163,174,179, 190,191,199,204,217, 220	100pF 50V CAP	375-5101	43
3	C5,22,78	1uF 50V ELEC CAP	381-5105	3
4	C6,11,19,20,23,42,56, 57,200	22pF 50V NPO CAP	373-5220	9
5	C15,16,68,85,101,108	470uF 25V ELEC CAP	381-3471	6
6	C18,30,33	2.2uF 35V ELEC CAP	381-42R2	3
7	C21,35,58,59,61,98	10uF 16V ELEC CAP	381-2100	6
8	C24	47uF 25V ELEC CAP	381-3470	1
9	C25,43,48,53,150,152, 172,187	.47uF 16V Y5V CAP	375-2474	8
10	C26,132	1000pF 50V X7R CAP	375-5102	2
11	C28,29,37,38,40,41, 45,46,50,51	10000pF 100V CAP	372-7103	10
12	C36,176,210,212,213	.22uF 16V Y5V CAP	375-2224	5
13	C44,47,49,54,55,62, 104	1uF 35V TANT CAP	392-4105	7
14	C60,138,196	330pF 50V CAP	375-5331	3
15	C64,65	18pF 50V CAP	375-5180	2
16	C67	2700pF 50V X7R CAP	375-5272	1

17	C73,137,139,167,170, 185,186,188,189	2.2uF 16V X5R CAP	375-22R2	9
18	C79,80	33pF 50V NPO CAP	375-5330	2
19	C81,83,102,141	.01uF 50V X7R CAP	375-5103	4
20	C87,88,106	47uF 16V ELEC CAP	381-2470	3
21	C105	47uF 6.3V ELEC CAP	381-0470	1
22	C151,198	1uF 16V X7R CAP	375-2105	2
23	D1,2	MMSZ5248B 18V ZEN DIODE	112-0301	2
24	D3,4,6,7,13	BAS21 200V SW DIODE	110-2203	5
25	D5	DDZ5V1B 5.1V ZEN DIODE	112-2403	1
26	D8	BZT52C3V3 3.3V ZEN DIODE	110-2150	1
27	D9,10	MMBD4148SE DIODE	110-2210	2
28	D11,16,17	SMA 30V 3A SCHOT DIODE	110-2305	3
29	D12,18	SS24 SCHOT DIODE	110-2304	2
30	D14,15	SUPER RED 0603 LED	112-0201	2
31	F1	FUSE RESETABLE 2.5A	290-1003	1
32	J1	INSERT CKFE440-4	200-0306	1
33	J2	2 POS .156 POST CONN	231-1067	1
34	J4	5 POS POST CONN	231-1005	1
35	J5	UNIVERSAL 8 TO 6 JACK	231-0007	1
36	J6	6 POS MODULE JACK	234-0066	1
37	J7	R/A POWER CONN	234-0114	1
38	J8	4 POS .1 LOCK HDR CONN	234-0014	1
39	J9	FT PTT JACK 3.5MM CONN	234-0085	1
40	J10	16 PIN DIP SOCKET	220-0001	1
41	J11	4 POS MODULE JACK	231-0021	1
42	J12	20 POS .100 HDR CONN	231-1091	1
43	J13	7 POS .1 LOCK HDR CONN	234-0006	1
44	J14	HEADSET JK 2.5MM CONN	234-0116	1
45	J15	6 POS POST CONN	231-1006	1
46	J18	SPEAKER JK 3.5MM CONN	234-0091	1
47	JP1,2,3,4,5,6,7,8,9,10, 11,12,13,14,15,16,17, 19	2 POS GOLD POST CONN	231-1002	18
48	JP18	4 POS LOCKING CONN	234-0014	1
49	L1	47.00uH POWER IND	306-3001	1
50	L2	33.00uH POWER IND	306-3002	1
51	MK1	EM-80 MIC ELEMENT	901-0010	1
52	Q1,2,3,4,5,6	MMBT4401-7-F TRANS	110-2206	6
53	Q7,8	2N7002 TRANS	180-1003	2
54	R1	50K SLIDE/AUDTAP POT	340-0003	1
55	R2,12,73,74,133	100 1% 1/16 W RES	322-1000	5
56	R3,113,123,149	6.8K 5% 1/10 W RES	323-1682	4
57	R5,7,8,9,10,13,14,15 16,18,20,48,49,61,62 65,71,79,80,81,83,85 88,92,95,97,99,103 107,118,120,128,129 136,138,141,155,156 157,159,160,161,162 164,165	10K 5% 1/10 W RES	323-1103	45

58	R6,17,33	75K 5% 1/10 W RES	323-1753	3
59	R11,41,55,58,63,68,69 75,76,98	1K 5% 1/10 W RES	323-1102	10
60	R19,45,46,47,70,72 137,139,171	0 5% 1/10 W RES	323-0000	9
61	R21,112	1.78K 1% 1/16 W RES	322-1781	2
62	R22	620 5% 1/10 W RES	323-1621	1
63	R23,143,146,154,166 170	12K 5% 1/10 W RES	323-1123	6
64	R24,42,54,56,96,140	4.7K 5% 1/10 W RES	323-1472	6
65	R25,50	680 5% 1/10 W RES	323-1681	2
66	R26,147	2.67K 1% 1/16 W RES	322-2671	2
67	R27,109,110,144	46.4K 1% 1/16 W RES	322-4642	4
68	R28,29,32,39,40	2K 22 T TOP ADJ POT	352-0004	5
69	R30	22K 5% 1/10 W RES	323-1220	1
70	R31,108,134,145,158 167,168,169	24K 5% 1/10 W RES	323-1243	8
71	R34	1K 1% 1/4 W RES	326-1001	1
72	R35,36	9.31K 1% 1/4 W RES	326-9311	2
73	R37,52,135,153	10 5% 1/10 W RES	323-1100	4
74	R38,51,82	33K 5% 1/10 W RES	323-1333	3
75	R43,93	470K 5% 1/10 W RES	323-1474	2
76	R44,59	1M 1% 1/16 W RES	322-1004	2
77	R53	27K 5% 1/10 W RES	323-1273	1
78	R57	390K 5% 1/10 W RES	323-1394	1
79	R60	7.15K 1% 1/4 W RES	326-7151	1
80	R77,78	2K 5% 1/10 W RES	323-1202	2
81	R84,126	3.0K 5% 1/10 W RES	323-1302	2
82	R86	4.7M 5% 1/10 W RES	323-1475	1
83	R87,104	330 5% 1/10 W RES	323-1331	2
84	R89	330K %5 1/10 W RES	323-1334	1
85	R90	6.8M 5% 1/10 W RES	323-1658	1
86	R91,94,114,121,150	3.9K 5% 1/10 W RES	323-1392	5
87	R100,125,132	220K 5% 1/10 W RES	323-1224	3
88	R101,102,152	100K 5% 1/10 W RES	323-1104	3
89	R105,106	10.0K 1% 1/16 W RES	322-1103	2
90	R111,148	7.32K 1% 1/16 W RES	322-7321	2
91	R115	2.2K 5% 1/10 W RES	323-1222	1
92	R117,119,122	7.15K 1% 1/16 W RES	322-7151	3
93	R124	750K 1% 1/16 W RES	322-7503	1
94	R127	40.2K 1% 1/16 W RES	322-4022	1
95	R130	11.8K 1% 1/16 W RES	322-1182	1
96	R131	374K 1% 1/16 W RES	322-3743	1
97	R142,151	6.2K 5% 1/10 W RES	323-1622	2
98	R163	51K 5% 1/10 W RES	323-1510	1
99	SG1,2,3,4	SMCJ30C 30V DIODE	112-0401	4
100	SW1,2,3	2.36 MM TACT SWITCH	616-0003	3
101	T2	AUDIO TRANSFORMER	410-0006	1
102	T3	AUDIO TRANSFORMER	410-0005	1

103	TP1,2,11,12,13,14,15 16,17,18,19	TEST POINT	200-0013	11
104	U1,4,5,6,10,12	TL064ID, IC	131-1098	6
105	U2,23,43	UMG2N, IC	131-5018	3
106	U3	TPA1517DWPR, IC	131-1061	1
107	U7,16,22,44,45	ADG444BRZ, IC	131-1096	5
108	U8,9,13	AD5263BRUZ50, IC	131-7003	3
109	U11	LM2903M, IC	131-1094	1
110	U14,21	LMH6639MF/NOPB, IC	131-5013	2
111	U15	SA572D, IC	131-1038	1
112	U18	ATTINY84-20SSU, IC	131-1097	1
113	U19	MX803ADW, IC	131-1099	1
114	U20	LM2673S-ADJ, IC	131-4001	1
115	U24	MT88L89, IC	131-1038	1
116	U26	LM2937IMP-10, IC	131-5010	1
117	U27	LM2673S-3.3, IC	131-4002	1
118	U28,30	SN74LVC2G240DCTR, IC	131-7005	2
119	U29	SN74AHC1G02DBVR, IC	131-5014	1
120	U31	74HC373, IC	131-1022	1
121	U32	SN74LVC2G34DBVR, IC	131-5016	1
122	U34, 35	SN74LVC1G175DBVR, IC	131-5012	2
123	U36	LM1086IS-5.0, IC	131-4003	1
124	U37	SN74AHC1G32DBVR, IC	131-5015	1
125	U38	LM2937IMP-5.0, IC	131-5011	1
126	U39	XC9572XL-10PC44C, IC	131-3010	1
127	U40	FM24CL64B-GTR, IC	131-1102	1
128	U41	PIC24FJ128GA006, IC	131-8000	1
129	U42	MAX 6412, IC	131-5017	1
130	Y1	3.579545 MHZ LO, CRYSTAL	305-0106	1
131	Y2	4.00 MHZ 20 PF, CRYSTAL	305-0108	1
132		RUBBER ELEMENT HOLDER	901-0011	1
133		24-67 BASE PC BOARD	900-0310	1

**24-67 MSK Control Option
106-MSK67OPT**

Item	Reference	Description	Part No.	Qty.
1	U25	MX429, IC	131-3003	1
2	U33	74LVC4245A, IC	131-5019	1
3	Y3	4.00 MHZ 20 PF, CRYSTAL	305-0108	1

**Supervisory/Alternate Line Option
431-RBC-712**

Item	Reference	Description	Part No.	Qty.
1	K1	4PDT RELAY	700-0001	1

**Keypad Board
101-KEYPADRM**

Item	Reference	Description	Part No.	Qty.
1	C1,2	10uF 16V ELEC CAP	360-0004	2
2	C3	10uF 16V TANT CAP	390-0010	1
3	C4,6	NOT INSTALLED	000-0002	2
4	C5	.1uF 50V 10% MONO CAP	365-5104	1
5	D1	NOT INSTALLED	000-0002	1
6	D2,3,4,5,6,7,8,9,10, 11,12,13	LED, T-1 RED	112-0012	12
7	D14	LED, RED HIGH INTENSITY	112-0024	1
8	J1,2,3,4	NOT INSTALLED	000-0002	4
9	J5	16 POS CABLE 8"	222-0025	1
10	JP1,2	STAPLE JUMPER	265-0016	2
11	R1,6	220 1 W RES	314-1224	2
12	R2	1.2K 5% 1/4 W RES	312-0034	1
13	R3,5,7	10K 5% 1/4 W RES	312-0011	3
14	R4	33K 5% 1/4 W RES	312-0014	1
15	R8	NOT INSTALLED	000-0002	1
16	U1	MAX7219, IC	130-0287	1
17	U2	NOT INSTALLED	000-0002	1
18		KEYPAD PC BOARD	900-0209	1

VU Meter Option (New)

Item	Reference	Description	Part No.	Qty.
1	D1,2	10 SEGMENT BAR LED	112-0027	2
2	P1	12 POS HEADER POST	231-3315	1
3	U2	LM3915 IC	130-0372	1
4		PLASTIC STANDOFF .125"	200-0388	2
5		VU METER PC BOARD	900-0281	1

Clock Option

Item	Reference	Description	Part No.	Qty.
1	J4	24 PIN DIP SOCKET	220-0019	1
2	J4	LED CLOCK DISPLAY	113-0098	1

Frequency Display Option

Item	Reference	Description	Part No.	Qty.
1	D1	7 SEG RED, DISPLAY	113-0099	1
2	D1	14 PIN DIP SOCKET	220-0002	1
3	J2	6 POS BOTTOM ENTRY CON	231-1116	2

LCD Option

Item	Reference	Description	Part No.	Qty.
1	C4,6	.1uF 50V 10% MONO CAP	365-5104	2
2	J1	6 POS RECEPTACLE	231-1116	2
3	J3	8 POS RECEPTACLE	231-3008	2
4	R8	10K 1 TURN POT	351-1103	1
5	U2	74HC595, IC	130-0350	1
6		LCD 32 CHARACTER	113-0104	1
7		PLASTIC STAND OFF 3/16"	200-0385	4
8		16 POS HEADER POST	231-3116	1

DC Power Cable Option

Item	Description	Part No.	Qty.
1	2 POS .156 RECEPTACLE	233-0024	1
2	CABLE TIE (SHORT)	200-0081	1
3	2 COND. 20ga. CABLE	800-1106	5'

External Encode/Decode Cable Option 431-RBC-702

Item	Description	Part No.	Qty.
1	CABLE TIE (SHORT)	200-0081	1
2	9 COND. 22ga. CABLE	222-0034	3'
3	7 POS .1" RECEPTACLE	234-0007	1

Phone Cable Option

Item	Description	Part No.	Qty.
1	4 POS. MODULAR PLUG	231-0006	2
2	WIRE 4 CON, TELE. FLAT	800-1002	10'

Programming Cable Option 431-RBC-003

Item	Reference	Description	Part No.	Qty.
1	C1,2,3,4	10uF TANT CAP	390-9106	4
2	J1	IDC PC MOUNT PIN	231-0041	4
3	J2	DB25 W/FEMALE PIN	231-0022	1
4	U1	MAX232, IC	130-0235	1
5		DB25 HOOD COVER	231-0046	1
6		CABLE ASSEMBLY	800-2027	1
7		PROGRAMMING CABLE PCB	900-0215	1

Desk Mic Option

Item	Description	Part No.	Qty.
1	DESK MIC	900-0399	1
2	CRYSTAL PROGRAMMABLE	900-0725	1
3	CABINET TOP for LED	900-0721	1
4	CABINET TOP for LCD	900-0750	1

Hand Set Option

Item	Description	Part No.	Qty.
1	HOLE COVER	199-6137	1
2	CABLE TIE (SHORT)	200-0081	2
3	SENSOR SWITCH	611-0027	1
4	HAND SET	900-0020	1
5	CABINET TOP for LED	900-0723	1
6	CABINET TOP for LCD	900-0751	1

DTMF Pad Option

Item	Description	Part No.	Qty.
1	5 POS RECEPTACLE	233-0035	1
2	DTMF KEYPAD	903-0006	1

Wall Mount Option

Item	Description	Part No.	Qty.
1	#6 X 1/4" SF THRD SCREW	199-4039	4
2	#6 X 1" WALL SCREW	199-4011	4
3	WALL ANCHOR	199-4012	4
4	WALL MOUNT BRACKET	900-5112A	1

24-67 Base Cabinet

Item	Description	Part No.	Qty.
1	NUT PAL	199-0040	4
2	#6 FLAT WASHER	199-2106	2
3	6-32 X 1/4" SCREW	199-3070	1
4	#4 X 1/4" TAP SCREW	199-4029	9
5	#6 X 3/8" TAP SCREW	199-4038	7
6	#6 X 1/4" TAP SCREW	199-4039	6
7	6 KEY, KEYPAD	203-0026	1
8	3 KEY, KEYPAD	203-0027	2
9	3/8" FOOT	203-1053	4
10	22 AWG WIRE GREEN	222-0016	6"
11	22 AWG WIRE YELLOW	222-0018	6"
12	4 POS RECEPTACLE	233-0045	1
13	REMOTE BUTTON	900-0718	12
14	12 KEY PANEL SCREENED	900-0722S	1
15	BOTTOM CABINET TONE	900-0724T	1
16	CRYSTAL for LCD	900-0734	1
17	WEIGHT VoIP	900-5008A	1
18	3W 4ohm SPEAKER	901-0004	1
19	WALL TRANSFORMER	902-0015	1

TEST MODE APPENDIX

Keypad Layouts

The 24-67 Test Mode uses different keypad layouts to accept input from the User. The following are the non-test specific keypad layouts:

General Keypad Layout

The General Keypad Layout is used when referencing the keypad by key number.

Key 1	Key 2	Key 3
Key 4	Key 5	Key 6
Key 7	Key 8	Key 9

Key 10	Key 11	Key 12
--------	--------	--------

Selection Keypad Layout

The Selection Keypad Layout is used when selecting values from a list.

- Up increases a value or moves up in the list of options
- Down decreases a value or moves down in the list of options.
- Cancel stops the current operation.
- Ok stops the current operation and saves the result if possible. It is also used to answer a Yes or No question as Yes.

Up		
Down		
Cancel		

Ok		
----	--	--

Entering Test Mode

The Test Mode is included in the application code. The Test Mode is reached in one of two ways:

- Press Key 1 and Key 3 simultaneously before the main run-mode screen is displayed.
- Press PCB switch SW2 at any time the unit is operating.

Test Mode Main Menu

When entering Test Mode or returning from a Test Menu Item, “Choose Test” will be displayed on the 24-67 LCD Display. At this point, all outputs will be off. The audio gates will be set to allow audio from the line to the audio processors. All other gates will be off.

Select a test by pressing its corresponding number using the General Keypad Layout.

1. I/O Tests
2. Adjust Pots
3. Sequential Tone Encode
4. Tone Encode
5. DTMF Encode
6. Sequential Tone Decode
7. DTMF Decode
8. Serial Port
9. Set Parameters
10. Reset to Defaults

I/O Tests

This is a series of short tests to test the inputs and outputs of the 24-67, as well as insure that the rest of the tests operate smoothly. This test is entered by pressing Key 1 from the main test menu.

Test Outputs

This is the first of the I/O tests. To skip this test, press Ok using the Selection Keypad Layout while the display shows “SKIP TEST?” The test will be entered if any other key, or approximately 5 seconds has passed with no key activity.

The LCD display will show “TEST OUTPUTS” upon entering this test. While the test is running, the outputs below will alter states, once per second.

State #1	State #2
LED_1 On	LED_1 Off
LED_2 Off	LED_2 On
TEST_OUT_1 On	TEST_OUT_1 Off
TEST_OUT_2 Off	TEST_OUT_2 On
Relay Active	Relay Inactive

This test will complete automatically after the defined number of iterations has been executed. To exit the test manually, press any keypad button.

An error will be displayed if communications with IC's required to execute this test fail.

Test SW1 & SW2

This is the second of the I/O tests. It is entered at the successful completion of the previous test. To skip this test, press Ok using the Selection Keypad Layout while the display shows "SKIP TEST?" The test will be entered if any other key, or approximately 5 seconds has passed with no key activity.

The outputs from the previous test will change depending on the state of SW1 and SW2. The LCD display will show "Test SW1 & SW2" during this test.

SW1 Pressed	SW2 Pressed	Neither Pressed
LED_1 On	LED_2 On	LED_1 & LED_2 Off
TEST_OUT_1 On	TEST_OUT_2 On	TEST_OUT_1 & TEST_OUT_2 Off
Relay Active		Relay Inactive

This test will automatically end after changes in SW1 and SW2 are not detected for 15 seconds. To exit the test manually, press both SW1 and SW2 simultaneously.

To pass this test, each of the PCB switches, SW1 and SW2, must have been detected as both pressed and released.

Test PTT I/O

This is the third of the I/O tests. It is entered if there were no errors in the previous tests. To skip this test, press Ok using the Selection Keypad Layout while the display shows "SKIP TEST?" The test will be entered if any other key, or approximately 5 seconds has passed with no key activity.

During this test, the LCD display will show "PTT IO TEST" on the top line. The LED_1 and the LCD display's bottom line will show which inputs are active.

Handset PTT / DeskMic PTT Active	Encode/Decode Header PTT Input Active	Footswitch PTT Active	All PTT Inputs Inactive
LED_1 On "LOC"	LED_1 On "ENC"	LED_1 On "FT"	LED_1 Off -

This test will automatically end after any of the inputs in this test have not changed state for 15 seconds. To exit the test manually, press both SW1 and SW2 simultaneously or press any keypad button.

To pass this test, each of the inputs in this test must have been detected as both active and inactive.

Hookswitch Test

This is the fourth of the I/O tests. It is entered if there were no errors first two tests. To skip this test, press Ok using the Selection Keypad Layout while the display shows "SKIP TEST?" The test will be entered if any other key, or approximately 5 seconds has passed with no key activity.

During this test, the LCD display will show "TEST HOOK SWITCH" on the top line. The LED_2 and the LCD display's bottom line will if the input is active.

Handset Hook Active	Handset Hook Inactive
LED_2 On "ACTIVE"	LED_2 Off -

This test will automatically end after any of the inputs in this test have not changed state for 15 seconds. To exit the test manually, press both SW1 and SW2 simultaneously or press any keypad button.

To pass this test, each of the inputs in this test must have been detected as both active and inactive.

Monitor Test

This is the fifth of the I/O tests. It is entered if there were no errors first two tests. To skip this test, press Ok using the Selection Keypad Layout while the display shows "SKIP TEST?" The test will be entered if any other key, or approximately 5 seconds has passed with no key activity.

During this test, the LCD display will show "TEST MONITOR" on the top line. The LED_2 and the LCD display's bottom line will show which inputs are active.

Deskmic Monitor Active	Deskmic Monitor Inactive
LED_2 On "ACTIVE"	LED_2 Off -

This test will automatically end after any of the inputs in this test have not changed state for 15 seconds. To exit the test manually, press both SW1 and SW2 simultaneously or press any keypad button.

To pass this test, each of the inputs in this test must have been detected as both active and inactive.

Keypad Test

This is the last of the I/O tests. At the start of this test, the LCD display will show “Test Keypad. Press all keys”. All of the keypad button LEDs will be off. The faceplate’s transmit light will be on throughout this test.

When a keypad button is pressed, the LED next to the key will on for the remainder of the test.

This test will automatically end after a change in the keypad is not detected for 15 seconds. To exit the test manually, and to pass this test, each of the keypad buttons must have been pressed.

If all keypad buttons have not been pressed, the LEDs remain unchanged until the error is cleared.

Adjust Pots

This test is entered by pressing Key 2 from the main test menu. In addition to the General Keypad Layout, this test also uses the following keypad mappings:

Source Adjust Keypad Layout

The Source Adjust Keypad Layout is used when the adjustment allows changing which source is used in adjusting the pot. A ‘S’ will show on the lower right of the LCD display to show that the Source Adjustment Keypad Layout is in effect. The LED next to the source button will be illuminated to show which source paths are active. Note that some adjustments disable some of the source options and will be enumerated in that adjustment description.

- **Value Up** increases the pot’s value. Holding this key down will continue to increase the pot’s value.
- **Value Down** decreases the pot’s value. Holding this key down will continue to increase the pot’s value.
- **Cancel** leaves the adjustment. The pot will be set to the last value saved.
- **Save** stores the current value in non-volatile memory before leaving the adjustment.
- **Line Receive** selects line audio from J5/J6 as a source signal. By default, the adjustment will use the two or four wire mode setting stored in non-volatile memory. Exceptions will be noted in the adjustment description.
- **Headset Mic** selects J14-2 as a source signal.
- **DTMF Encoder** selects U24 as a source signal. A DTMF tone ‘1’ is generated.
- **MSK Encoder** will be developed in a future release.
- **Internal Mic** selects MK1 as a source signal.
- **Handset Mic** selects J11-4 as a source signal.

Value Up	Line Receive	Internal Mic
Value Down	Headset Mic	Handset Mic
Cancel	DTMF Encoder	Tone Encoder

Save	MSK Encoder	Encode/Decode Header Audio
------	-------------	----------------------------

Source Adjust Keypad Layout (cont.)

- **Tone Encoder** selects U19 as a source signal. If Guard Tone is required for the adjustment, a 2175 Hz tone is generated. If Guard Tone is not required for the adjustment, a 1050 Hz tone is generated.
- **Encode / Decode Header Audio** selects J13-5 as a source signal.

Destination Adjust Keypad Layout

The Destination Adjust Keypad Layout is used when the adjustment allows changing which destination to use when adjusting the pot. A 'D' will show on the lower right of the LCD display to show that the Destination Adjust Keypad Layout is in effect. The LED next to the destination button will be illuminated to show which destination paths are active. Note that some adjustments disable some of the destination options and will be enumerated in that adjustment description.

- **Value Up** increases the pot's value. Holding this key down will continue to increase the pot's value.
- **Value Down** decreases the pot's value. Holding this key down will continue to decrease the pot's value.
- **Cancel** leaves the adjustment. The pot will be set to the last value saved.
- **Save** stores the current value in non-volatile memory before leaving the adjustment.
- **Line Transmit** selects line audio to J5/J6 as a destination for the signal.
- **Headset Ear** selects J14-4 (Headset Earpiece) as a destination for the signal.
- **Speaker** selects J8 and J18 as a destination for the signal. Note that this destination is dependent on the setting of JP2 and JP18.
- **Handset Ear** selects J11-2 (Handset Earpiece) as a destination for the signal, regardless of the corresponding configuration value stored in non-volatile memory.

Value Up	Line Transmit	Speaker
Value Down	Headset Ear	Handset Ear
Cancel		
Save		

Pot Selection

Select a pot to adjust by pressing its corresponding number using the General Keypad Layout.

1. Internal Mic (U13B)
2. Handset Mic (U13C)
3. Transmit Audio (U9C)
4. DTMF Encoder (U9D)
5. Tone Encoder (U9B)
6. MSK Encoder (U9A)
7. 2 Wire (U8C)
8. 4 Wire (U8B)
9. Speaker (U8A)
10. Handset Ear (U8D)
11. Handset Ear (U13D)
12. 2175Hz Detect (U13A)

Adjusting Internal Mic (U13B)

This adjustment is reached by pressing Key 1 when the “POT TO ADJUST?” menu item is displayed on the LCD display. This adjustment uses the Destination Adjust Keypad Layout. The signal source for this adjustment is **Internal Mic**.

Adjusting Handset Mic (U13C)

This adjustment is reached by pressing Key 2 when the “POT TO ADJUST?” menu item is displayed on the LCD display. This adjustment uses the Destination Adjust Keypad Layout. The signal source for this adjustment is **Handset Mic**.

Transmit Audio (U9C)

This adjustment is reached by pressing Key 3 when the “POT TO ADJUST?” menu item is displayed on the LCD display. This adjustment uses both the Source Adjustment Keypad Layout when the Handset/Deskmic PTT line (J11-3) is inactive. It uses the Destination Adjust Keypad Layout when the Handset/Deskmic PTT line (J11-3) is active.

DTMF Encoder (U9D)

This adjustment is reached by pressing Key 4 when the “POT TO ADJUST?” menu item is displayed on the LCD display. This adjustment uses the Destination Adjust Keypad Layout without the ability to turn off the destination **Line Transmit**. The signal source for this adjustment is **DTMF Encoder**. A DTMF ‘1’ is encoded continuously during this adjustment.

Tone Encoder (U9B)

This adjustment is reached by pressing Key 5 when the “POT TO ADJUST?” menu item is displayed on the LCD display. This pot operates using two separate values, one when encoding Guard Tone, and another when encoding Function Tone. The LCD display will show “GUARD TONE?” Press ‘Ok’ using the Selection Keypad Layout to enter the Guard Tone Level Adjustment. Any other key will enter the Function Tone Level Adjustment.

Guard Tone Level Adjustment

This adjustment is reached by pressing ‘Ok’ when the LCD display shows “GUARD TONE?” This adjustment uses the Destination Adjust Keypad Layout, without the ability to turn off the destination **Line Transmit**. The signal source for this adjustment is **Tone Encoder**. A 2175 Hz tone is generated by the Tone Encoder (U19) during this adjustment.

Function Tone Level Adjustment

This adjustment is reached by pressing any key other than ‘Ok’ when the LCD display shows “GUARD TONE?” This adjustment uses the Destination Adjust Keypad Layout, without the ability to turn off the destination **Line Transmit**. The signal source for this adjustment is **Tone Encoder**. A 1050 Hz tone is generated by the Tone Encoder (U19) during this adjustment.

MSK Encoder (U9A)

This adjustment is reached by pressing Key 6 when the “POT TO ADJUST?” menu item is displayed on the LCD display. This adjustment uses the Destination Adjust Keypad Layout, with **Line Transmit**, **Headset Ear**, **Speaker**, and **Handset Ear** disabled. This adjustment will be refined in a future version of the 24-67.

2 Wire (U8C)

This adjustment is reached by pressing Key 7 when the “POT TO ADJUST?” menu item is displayed on the LCD display. This adjustment uses the Destination Adjust Keypad Layout without the ability to set the destination to **Line Transmit**. The signal source for this adjustment is **Line Receive**. The Two wire mode will be used for this test regardless of the setting stored in non-volatile memory.

4 Wire (U8B)

This adjustment is reached by pressing Key 8 when the “POT TO ADJUST?” menu item is displayed on the LCD display. This adjustment uses the Destination Adjust Keypad Layout without the ability to set the destination to **Line Transmit**. The signal source for this adjustment is **Line Receive**. The Four wire mode will be used for this test regardless of the setting stored in non-volatile memory.

Speaker (U8A)

This adjustment is reached by pressing Key 9 when the “POT TO ADJUST?” menu item is displayed on the LCD display. This adjustment uses the Source Adjust Keypad Layout. The destination for this adjustment is **Speaker**.

Headset Ear (U8D)

This adjustment is reached by pressing Key 10 when the “POT TO ADJUST?” menu item is displayed on the LCD display. This adjustment uses the Source Adjust Keypad Layout. The destination for this adjustment is **Headset Ear**.

Handset Ear (U13D)

This adjustment is reached by pressing Key 11 when the “POT TO ADJUST?” menu item is displayed on the LCD display. This adjustment uses the Source Adjust Keypad Layout. The destination for this adjustment is **Handset Ear**.

2175Hz Detect (U13A)

This adjustment is reached by pressing Key 12 when the “POT TO ADJUST?” menu item is displayed on the LCD display. This adjustment uses the Source Adjust Keypad Layout with only ‘Value Up’, ‘Value Down’, ‘Cancel’, and ‘Save’ enabled. The signal source for this adjustment is **Line Receive**.

Sequential Tone Encode

This test is entered by pressing Key 3 from the main test menu. The top line on a LCD display will show "Seq. Tone Encode". The second line will show the last sequential tone update that was sent to the line. Note that the nature of the sequential tone update is affected by the settings stored in non-volatile memory.

The Selection Keypad Layout is used in this test.

- **Up** and **Down** cycle through the list of standard Function Tones. The tone update for the selected Function Tone will be sent immediately.
- **Cancel** and **Ok** leave the test.

Additionally, the PTT inputs are used in this test. A tone update with Hold Tone will be encoded using the displayed Function Tone when one of the PTT inputs are active. When Hold Tone is present, the appropriate audio source is activated. The footswitch PTT input will use the internal microphone, regardless of the setting in non-volatile memory. Hold Tone will stop being encoded when all PTT inputs are inactive.

Tone Encode

This test is entered by pressing Key 4 from the main test menu. The top line on a LCD display will show "Test Tone Encode" though out this test.

The Selection Keypad Layout is used in this test.

- **Up** and **Down** cycle through the list of tones. The following is the list of tones available for encoding by this test.
 - **Guard Tone:** A 2175 Hz tone will be encoded out U19-16 to the line using the pot value for Guard Tone. The LCD display will show "ENCODING GUARD" on the second line.
 - **Function Tone:** A 1050 Hz tone will be encoded out U19-16 to the line using the pot value for Function Tone. The LCD display will show "ENCODING FUNCT." on the second line.
 - **Hold Tone:** A 2175 Hz tone will be encoded out U19-17 to the line using the pot value for Guard Tone. The LCD display will show "ENCODING HOLD" on the second line.
- **Cancel** or **Ok** are used to exit the test.

DTMF Encode

This test is entered by pressing Key 5 from the main test menu. The LCD display will show "TEST DTMF ENCODE".

During this test, the DTMF tone '1' is sent to the line and the speaker.

Press any key to exit this test.

Sequential Tone Decode

This test is entered by pressing Key 6 from the main test menu. The LCD display will show “TEST Seq. Tone” at the start of this test.

Upon reception of a tone update, the LCD display will show “SEQ. TONE DECODE” on the first line and the tone decoded on the second line. Note that the nature of the tone received and displayed is dependent on the settings stored in non-volatile memory.

Press any key to exit this test.

DTMF Decode

This test is entered by pressing Key 7 from the main test menu. The LCD display will show “TEST DTMF DECODE”, “ANY KEY EXITS”.

Upon reception of a DTMF from the line, the tone will be present at the speaker and handset earpiece. The LCD display will show “TEST DTMF DECODE” on the top line, followed by the last 16 DTMF characters that were decoded.

Press any key to exit this test.

Serial Port

This test is entered by pressing Key 8 from the main test menu. The LCD display will show “TEST SERIAL”, “ANY KEY EXITS”.

To execute this test, connect the programming cable to J5 and open a terminal program such as HyperTerm. Set the terminal program’s comport settings for 19200 baud, 8N1. All characters sent via the terminal program will be echoed back through the comport, preceded by a space.

Press any key to exit this test.

Set Parameters

This test mode option is entered by pressing Key 9 from the main test menu. The LCD display will show “Set Parameters”, “APPLIED ON SAVE”. The keypad layout for this test is shown in the following table.

- 4 Wire Mode: This key adjusts the current setting for the wire mode. If the LED is on, 4 Wire Mode is on. If the LED is Off, 2 Wire Mode is on. Press this key to toggle this setting.

4 Wire Mode	Speaker AGC	Processor AGC
Use Deskmic	Full Duplex	
Cancel		
Save		

- Speaker AGC: This key adjusts the current setting for Speaker AGC. If the LED is on, the AGC is enabled for the speaker circuit. If the LED is off, AGC will be bypassed going to the speaker circuit. Press this key to toggle the Speaker AGC setting.
- Processor AGC: This key adjusts the current setting for the Audio Processor Circuit AGC. If the LED is on, the AGC is enabled for the audio processors. If the LED is off, AGC will be bypassed going to the speaker circuit. Press this key to toggle the Processor AGC.
- Use Deskmic: This key adjusts the current setting for using the Deskmic. If the LED is on, the 24-67 expects a desk microphone to be connected to J11. If the LED is off, the 24-67 expects a handset to be connected to J11. Press this key to toggle using the Deskmic.
- Cancel: Press this key to abort this test mode option. Nothing will be written to non-volatile memory.
- Save: Press this key to save the settings displayed to non-volatile memory. The 24-67 will restart after the settings are saved.

Reset to Defaults

This test is entered by pressing Key 10 from the main test menu. The LCD display will show “DEFAULT PARAMETERS?”

To reset the configuration values to their default settings, press “Ok” using the Selection Keypad Layout. The 24-67 will restart after the configuration values are written to non-volatile memory.

To exit this test mode option without resetting the parameters to their default settings, press any key other than “Ok”.

INSTALLATION DIAGRAMS

Insert
24-67 Installation Diagram
here

Insert

24-67 Installation Diagram with Supervisory Control

here

ADJUSTMENT LOCATOR DIAGRAM

Insert
Adjustment Locator Diagram
here

SCHEMATICS

Insert
Schematics
here