

E.F. Johnson Viking GT Interface

The following items are included in the E.F. Johnson Viking GT cable interface kit:

1. E.F. Johnson Viking GT interface cable assembly.
2. Cable tie.
3. Instruction sheet.
4. 4 pieces of Heat Shrink Tubing
5. 4 pieces of Wire Wrap Wire

The following steps outline the procedure for interfacing the E.F Johnson Viking GT radio to the TrakIt-20.

1. Set the TrakIt-20 up for a bench test and use the AVL Installer program to set the following operating constants in the installer table to the indicated value:

Transmit indicator active:	High
Receive indicator active:	High
PTT output active:	Low
Enable mic mute gate on transmit:	Yes
Enable Tx indicator as event 2:	No
External output active:	Low
External output mode:	Speaker mute

2. Configure the following jumpers as indicated:

JP1 Removed
JP4 B-C

3. On the TrakIt-20 Board remove D2.
4. Remove cover of the radio.
5. Remove Audio/Logic Board from the radio and solder the enclosed lengths of wire wrap wire to the following points on the bottom of the Audio/Logic Board.

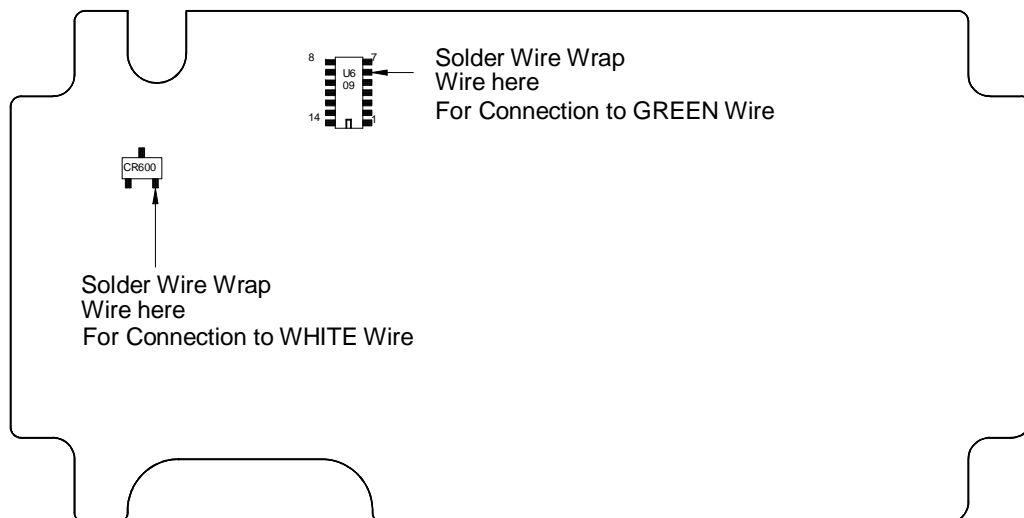

EFJ VIKING GT Audio/Logic Board
BOTTOM VIEW

E.F Johnson Viking GT Interface (cont.)

6. Keeping track of which wire wrap wire is which, pass them through the small hole by J300. Reinstall Audio/Logic PCB.
7. Connect the wires of the Viking GT interface cable to the following points in the radio as shown in the following diagrams:

Blue	J402 pin 1
Orange	W/O 13
Gray	Jct. of R607 and C624
Black	W/O 10 attach and heat shrink shield
Red	J300 pin 8
Yellow	J401 pin 4 attach using wire wrap wire
Violet	J401 pin 8 attach using wire wrap wire
Green	U609 pin 6 from the bottom of the Audio/Logic board (Wire wrap wire passed through board)
White	CR600 from the bottom of the Audio/Logic board (Wire wrap wire passed through board)

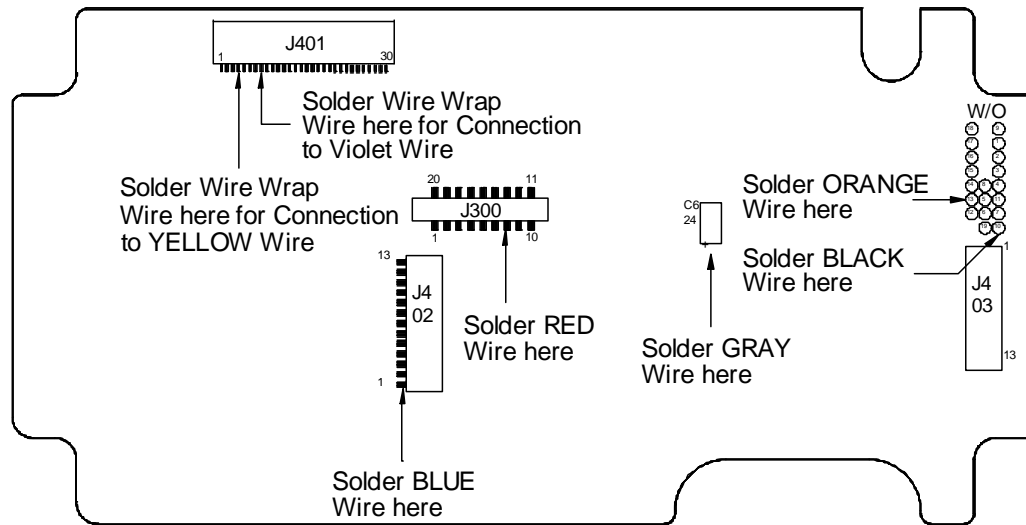

EFJ VIKING GT Audio/Logic Board
TOP VIEW

8. Replace cover of radio.
9. Connect the DB-15 end of the Viking GT interface cable to the DB-15 connector on the back of the Trakt-20.

E.F Johnson Viking GT Interface (cont.)

- Check the TrakIt-20's audio levels by performing the alignment procedure described in the TrakIt-20 manual.

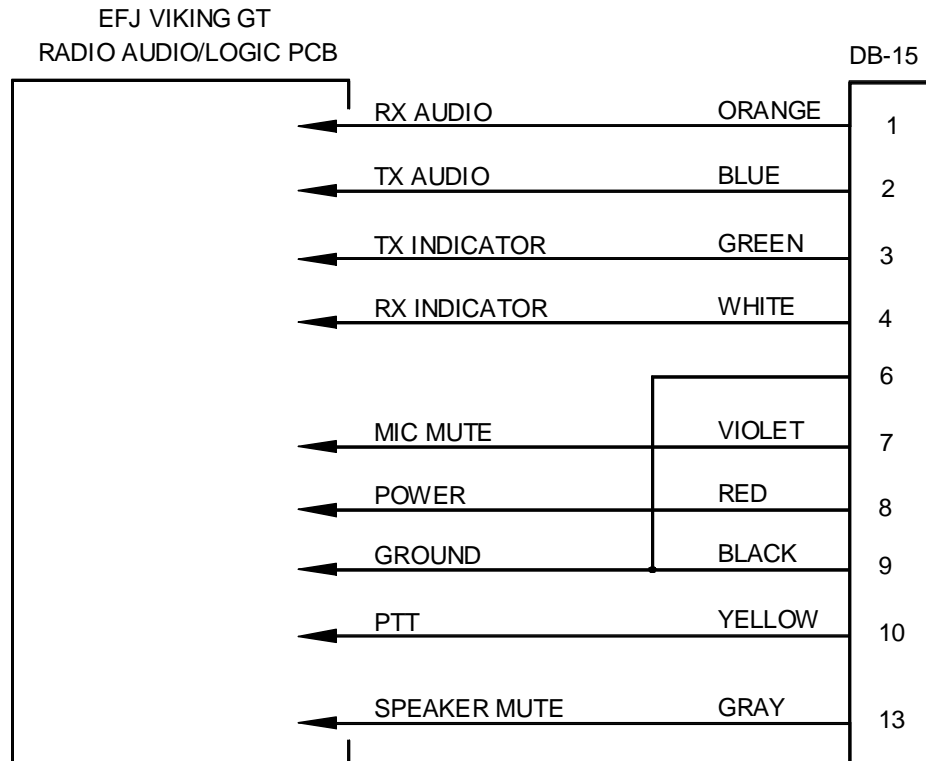

E.F. JOHNSON VIKING GT INTERFACE CABLE KIT 106-EFJVIGT

Item	Description	Part No.	Qty.
1	CABLE TIE (short)	200-0081	1
2	SCREW/CLIP KIT	231-0014	1
3	CONN DB15 MALE	231-0035	1
4	COVER DB15	231-0036	1
5	10 COND CABLE	800-1115	1'